

METAL ANCHORS

FOR LOAD BEARING CONNECTION

Ruumala OÜ

+372 5179107 (EST)

www.RUUMALA.com

Content Table

- 1. U Bar (UB) 3
- 2. Heavy Load U Bar (UB-HL and UB-HLX) 6
- 3. U Bar Angle (UB-A) 7
- 4. U Screw Bracket (US-BR) 8
- 5. UL and UF Bracket (UL-BR and UF-BR)..... 10
- 6. U Flat Hidden Bracket (UF-H) 12
- 7. U Floating Bracket (U-Float) 14
- 8. UL and UF Heavy Load Bracket (UL-HL BR and UF-HL BR) 16
- 9. Brick-Perforated Rail (B-PR) 18
- 10. Brick Static Tube (B-ST) 19
- 11. Secure Angle (SA) 20
- 12. Flat and U Angle (F-A and U-A) 22
- 13. Wall U Angle (WU-A) 24
- 14. Wall U Angle Adjustable (WUL-A and WUF-A) 27
- 15. Floating Angle (WU-Float) 29
- 16. Double U Angle and Flat Bar U Angle (DU-A and FBU-A) 30
- 17. Wall Mounting Bracket (WL-MBR and WF-MBR)..... 32
- 18. Frame Heavy Load Angle (FR-HL A) 34
- 19. Joist Heavy Load Bracket (J-HL BR) 36
- 20. Joist Heavy Load Bracket with Angle for base profile (J-HL BR-UA) 38
- 21. Base Profile Bracket (BP-BR) 40
- 22. Base Profile Heavy Load Angle (BP-HLA) 42
- 23. Adjusting Set (F-AS, L-AS and HBP-AS) 43
- 24. Fasteners (screws, dowels) 44
- 25. Force calculation, location of blocks and technical data..... 47

UB = U Bar

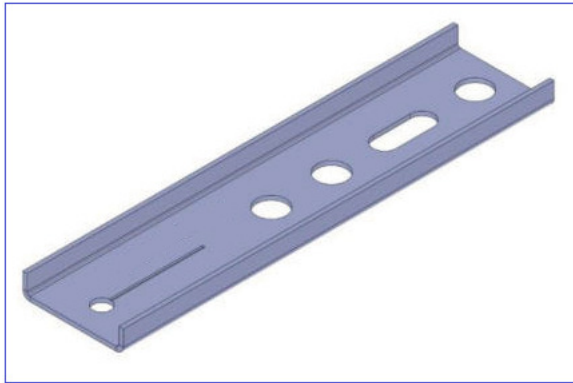

Article No.	Dimensions [mm]	PU
UB 150 S	150x35x1,5	50
UB 150 M	150x35x2,5	50
UB 200 S	200x35x1,5	50
UB 200 M	200x35x2,5	50
UB 250 S	250x35x1,5	50
UB 250 M	250x35x2,5	50
UB 250 L	250x35x3,0	50
UB 300 L	300x35x3,0	50
UB 350 L	350x35x3,0	50

Simple and fast mounting of windows in the insulation layer

Suitable for all systems (aluminium, wood, plastic)

The direct screwing through the window into the anchor is a proved wedging

Simple handling during modifications or replacing the window

Certified mounting to the masonry (hollow chequer brick, aerated concrete brick)

Window mounting in accordance with resistance class RC2

Suitable for fall-proof window mounting

Maximum load tested by ift-Rosenheim

Tested (ift-Rosenheim) for loads in the window layer: 11-003442-PR06, 14-002150-PR01, 18-003796-PR01							
1	Material thickness	Maximum load / bearing out A					
		30 mm	50 mm	70 mm	100 mm	130 mm	160 mm
	1,5 mm	136 kg	80 kg	44 kg			
	2,5 mm	175 kg	110 kg	58 kg	ca. 27 kg	ca. 14 kg	ca. 8 kg
	3,0 mm	ca. 208 kg	ca. 160 kg	114 kg	44 kg	27 kg	14 kg

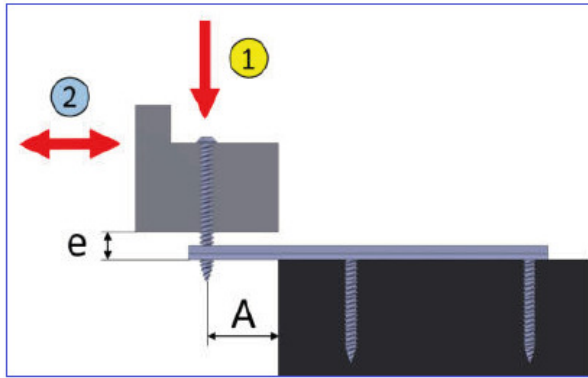

Tested (ift-Rosenheim) for loads right angled to the window layer: 18-000650-PR01		
	Gap e	maximum load
2	15 mm	227 kg
	25 mm	87 kg

Verified fall-proof window mounting.
ift-Rosenheim verification: 18-003796-PR07

Installation instruction

Preparation: 6.0 mm holes must be pre-drilled into the window frame.

Step 1: Place the window frame into the opening, align it and fix it by using, for example, wedges and blocks.

Step 2: Screw the $\varnothing 7.5$ mm Window Mounting Screw through the window frame until the tip of the screw becomes visible in the window seam.

Step 3: The U Bar anchor with the 6 mm drilled hole has to be placed over the tip of the screw and the Window Mounting Screw is screwed directly into the anchor.

Step 4: Connect the U Bar anchor with at least two mounting points to the masonry. This connection with the $\varnothing 7.5$ mm Window Mounting Screw is a wedging and RC2 resistance class approved.

That solution is also suitable when removing old windows that were installed with the U Bar anchor. The new window is mounted onto the existing U Bar anchors. If the drilled holes no longer fit, new holes can simply be drilled into the U Bar anchor.

U-Bar anchor as a mounting aid and window mounting from below

Attach the U Bar anchor to the right and left in the window opening and place the window onto it. Then align the height of the window by using mounting blocks.

In case of construction zones without insulation, screw the $\varnothing 7.5$ mm Window Mounting Screw through the anchor from below and screw the glazing blocks directly into the window sill connection profile.

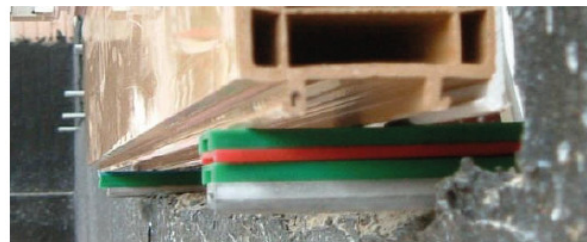

In case of construction zones with insulation, a connecting angle is used for the connection between the window and the U Bar anchor. The angle is fixed to the U Bar anchor with two Drilling Screws.

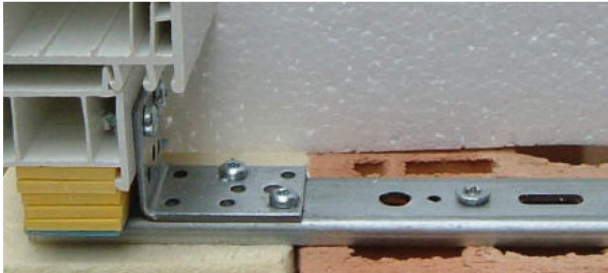

UB-HL and UB-HLX = Heavy Load U Bar

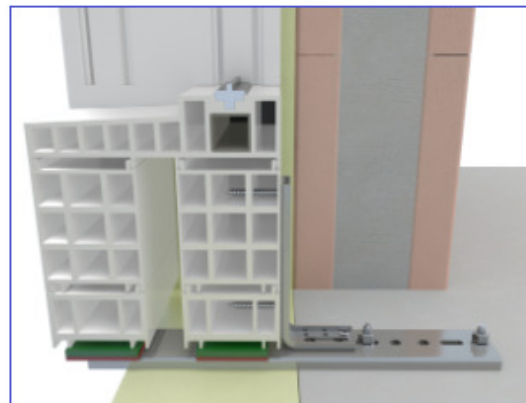
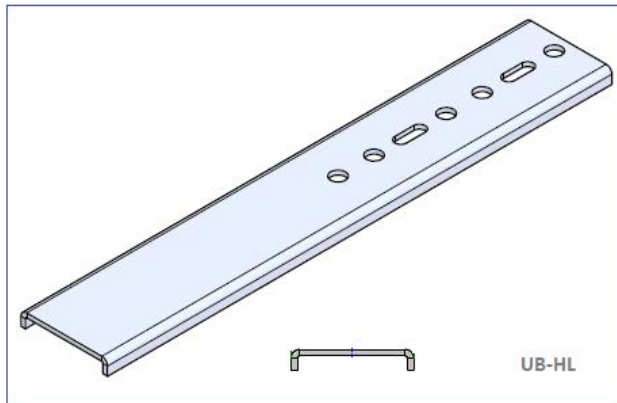

Article No.	Dimensions [mm]	PU
UB-HL 350 L	350x60x3,0	25
UB-HL 400 L	400x60x3,0	25

Internal test values		
	Bearing out A	Maximum load
1	100 mm	67 kg
	130 mm	44 kg
	160 mm	30 kg

Offers high load transference with a low space requirement

Maximum load tested by ift-Rosenheim

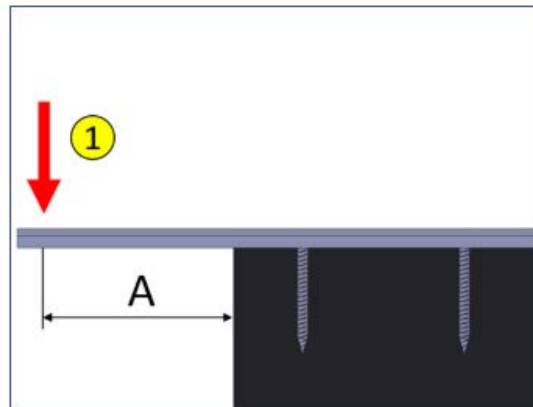
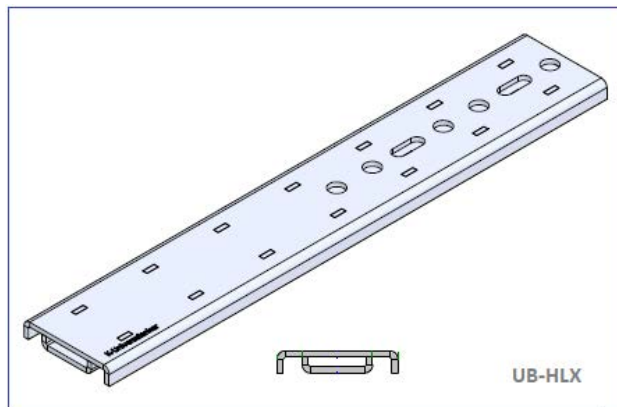

Article No.	Dimensions [mm]	PU
UB-HLX 350 L	350x60x3,0	25
UB-HLX 400 L	400x60x3,0	25

Tested (ift-Rosenheim) for loads in the window layer: 17-003399-PR01		
	Bearing out A	Maximum load
1	100 mm	135 kg
	130 mm	88 kg
	160 mm	60 kg

UB-A = U Bar Angle

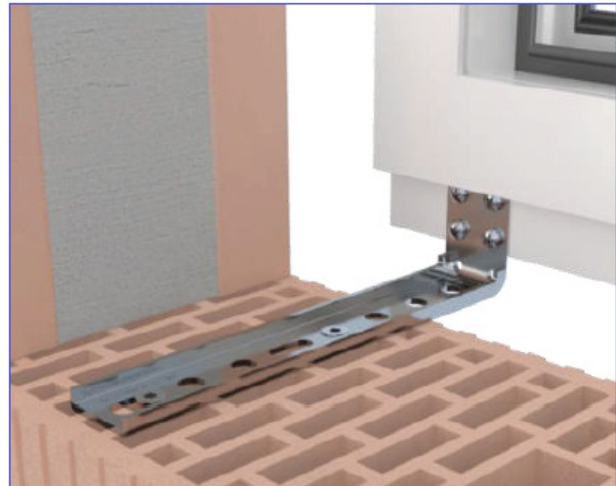
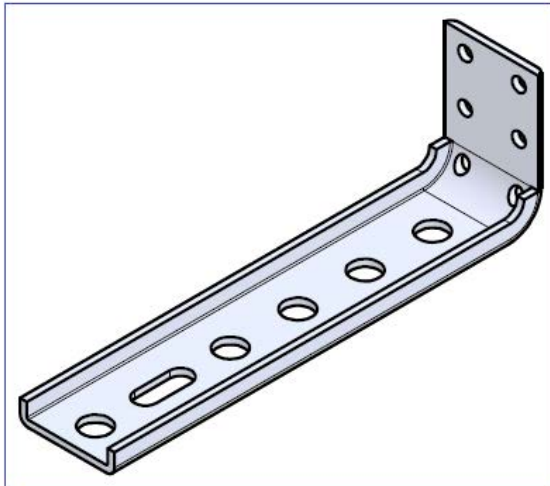

Article No.	Dimensions [mm]	PU
UB-A 30x160 M	30x160x35x2,5	50
UB-A 50x160 M	50x160x35x2,5	50
UB-A 70x165 M	70x165x35x2,5	50
UB-A 30x205 M	30x205x35x2,5	50
UB-A 50x210 M	50x210x35x2,5	50
UB-A 70x215 M	70x215x35x2,5	50
UB-A 30x255 M	30x255x35x2,5	50
B-A 50x260 M	50x260x35x2,5	50
UB-A 70x265 M	70x265x35x2,5	50
UB-A 30x280 M	30x280x35x2,5	50
UB-A 50x285 M	50x285x35x2,5	50
UB-A 70x290 M	70x290x35x2,5	50

Tested (ift-Rosenheim) for loads in the window layer: 11-003442-PR06, 14-002150-PR01, 18-003796-PR01							
	Material thickness	Maximum load / bearing out A					
		30 mm	50 mm	70 mm	100 mm	130 mm	160 mm
1	1,5 mm	136 kg	80 kg	44 kg			
	2,5 mm	175 kg	110 kg	58 kg	ca. 27 kg	ca. 14 kg	ca. 8 kg
	3,0 mm	ca. 208 kg	ca. 160 kg	114 kg	44 kg	27 kg	14 kg

Installation instruction

With the flat steel for the connection profile, we achieve the simple connection of the sealing foil, and because of the U Bar we have a certified load transference in the insulating layer.

For the wedging, the window must be positioned directly on the angle. For the wind load, the angle is screwed to the connection profile with at least two screws. This offers several options for a mounting to the masonry - especially in case of hollow concrete blocks in combination with the Brick-Perforated Rail.

US-BR = U Screw Bracket

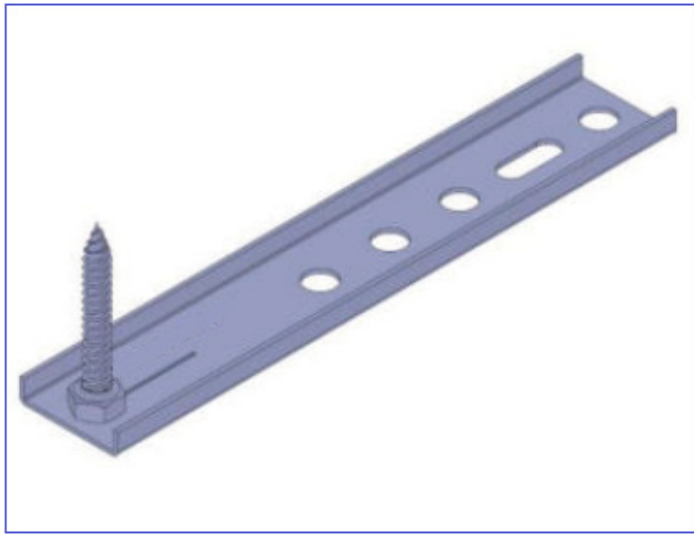

Article No.	Dimensions [mm]	PU
US-BR 150 S	150x35x1,5 - 62mm (Ø 7,5)	50
US-BR 150 M	150x35x2,5 - 62mm (Ø 7,5)	50
US-BR 200 S	200x35x1,5 - 62mm (Ø 7,5)	50
US-BR 200 M	200x35x2,5 - 62mm (Ø 7,5)	50
US-BR 250 M	250x35x2,5 - 62mm (Ø 7,5)	50
US-BR 300 L	300x35x3,0 - 62mm (Ø 7,5)	50
US-BR 350 L	350x35x3,0 - 62mm (Ø 7,5)	50

Suitable for all systems (aluminium, wood, plastic)

Window mounting without visible dowel holes

Well-suited for fixed windows with glued in glazing

Blocking-free mounting

Maximum load tested by ift-Rosenheim

Suitable for fall-proof window mounting

Tested (ift-Rosenheim) for loads in the window layer: 11-003442-PR06, 14-002150-PR01, 18-003796-PR01							
1	Material thickness	Maximum load / bearing out A					
		30 mm	50 mm	70 mm	100 mm	130 mm	160 mm
	1,5 mm	136 kg	80 kg	44 kg			
	2,5 mm	175 kg	110 kg	58 kg	ca. 27 kg	ca. 14 kg	ca. 8 kg
	3,0 mm	ca. 208 kg	ca. 160 kg	114 kg	44 kg	27 kg	14 kg

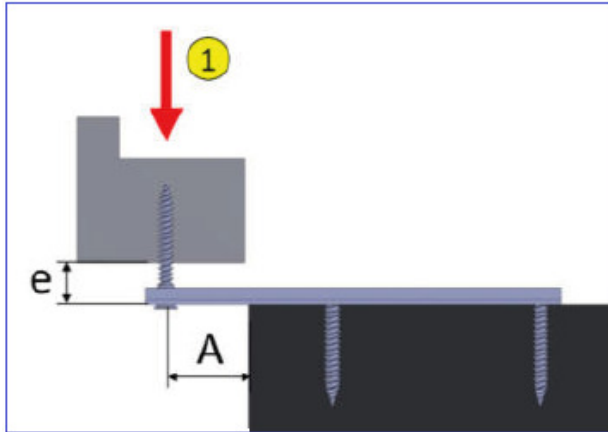

Installation instruction

Preparation: For window mounting with the US Bracket, 5.0 mm holes must be pre-drilled into the window frame.

The adjusting screw should be screwed in using a T30 bit until the expected joint widths are obtained and the element being installed can be inserted into the wall without difficulty. In case of PVC windows the adjusting screw should be screwed in at least 15 mm deep into the profile bottom and/or at least 10 mm deep into the steel strengthening piece.

The window frame should be installed onto the bottom adjustable Screw Bracket and prefixed horizontally with the assistance of the already attached Screw Brackets. Use the spanner or T30 bit for this purpose.

The remaining Screw Brackets to the left, right and top should be offered up flush against the intrados and/or the lintel and the window frame squared up to the window opening. All Screw Brackets should be appropriately predrilled in the structural walling in the centre of the longitudinal apertures of the relative bracket. After a final all-round check of the correct window frame position (vertical and horizontal), the installation screws can be screwed into the bearing wall. Predrill through the round holes of each bracket and lastly affix the window frame with the second (safety) screw into the walling.

UL-BR and UF-BR = UL and UF Bracket

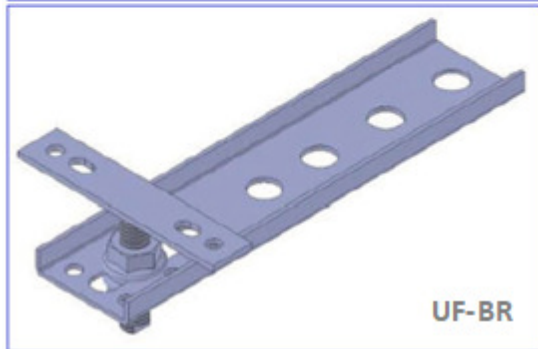
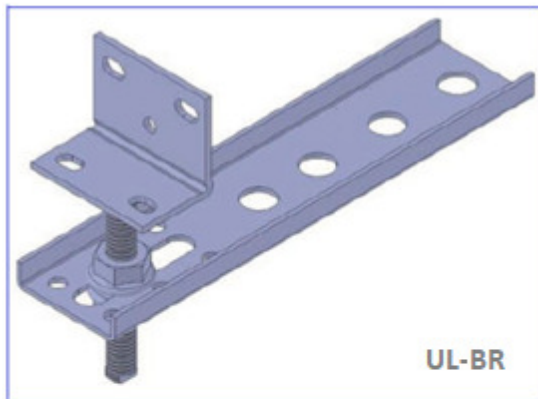

Article No.	Dimensions [mm]	PU
UL-BR 150 S6	150x35x1,5 - 60mm	50
UL-BR 200 S6	200x35x1,5 - 60mm	50
UL-BR 200 M6	200x35x2,5 - 60mm	50
UL-BR 250 M6	250x35x2,5 - 60mm	50
UL-BR 300 L6	300x35x3,0 - 60mm	50
UL-BR 300 L6	350x35x3,0 - 60mm	50
PU contain: 1 x U Bar + 1 x Adjusting Set (threaded pin with L-shape connection plate + 2 flange nuts M8)		

Article No.	Dimensions [mm]	PU
UF-BR 150 S4	150x35x1,5 - 40mm	50
UF-BR 150 S6	150x35x1,5 - 60mm	50
UF-BR 200 S4	200x35x1,5 - 40mm	50
UF-BR 200 S6	200x35x1,5 - 60mm	50
UF-BR 200 M4	200x35x2,5 - 40mm	50
UF-BR 200 M6	200x35x2,5 - 60mm	50
UF-BR 250 M4	250x35x2,5 - 40mm	50
UF-BR 250 M6	250x35x2,5 - 60mm	50
UF-BR 300 L4	300x35x3,0 - 40mm	50
UF-BR 300 L6	300x35x3,0 - 60mm	50
UF-BR 350 L4	350x35x3,0 - 40mm	50
UF-BR 350 L6	350x35x3,0 - 60mm	50
PU contain: 1 x U Bar + 1 x Adjusting Set (threaded pin with FLAT connection plate + 2 flange nuts M8)		

The UL-Bracket is suitable for mounting from below

The UF-Bracket is suitable for mounting from below and laterally

Suitable for all systems (aluminium, wood, plastic)

Adjustable in three dimensions to compensate structural tolerances

Application for height differences ranging from 12 mm to 50 mm

Blocking-free mounting

Window mounting in accordance with resistance class RC2

Maximum load tested by ift-Rosenheim

Tested (ift-Rosenheim) for loads in the window layer: 11-003442-PR06, 14-002150-PR01, 18-003796-PR01							
1	Material thickness	Maximum load / bearing out A					
		30 mm	50 mm	70 mm	100 mm	130 mm	160 mm
	1,5 mm	136 kg	80 kg	44 kg			
	2,5 mm	175 kg	110 kg	58 kg	ca. 27 kg	ca. 14 kg	ca. 8 kg
	3,0 mm	ca. 208 kg	ca. 160 kg	114 kg	44 kg	27 kg	14 kg

Tested (ift-Rosenheim) for loads right angled to the window layer: 12-002151-PR07		
2	Gap e	maximum load
	42 mm	68 kg

Verified fall-proof window mounting.
ift-Rosenheim verification: 18-003796-PR07

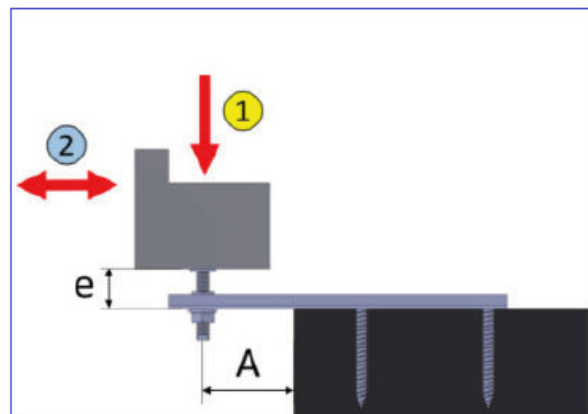
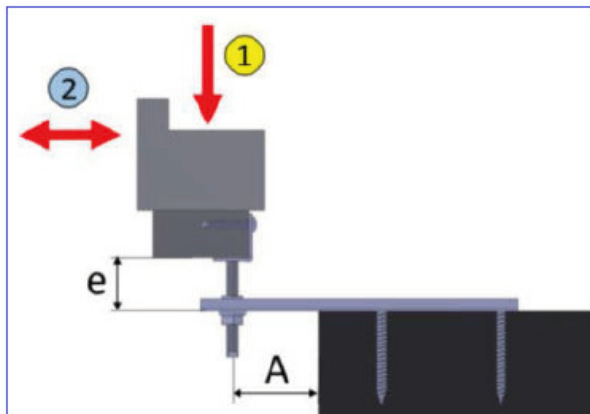

Installation instruction

The U Bar is fixed to the masonry, then the window is positioned on the adjusting detail and laterally adjusted and the angle connection is screwed to the window sill connection profile or to frame.

The height and depth of the window is readjusted. The adjusting detail is securely screwed into the slotted hole. For a smooth installation, we recommend a seam spacing of 15-35 mm.

UF-H = U Flat Hidden Bracket

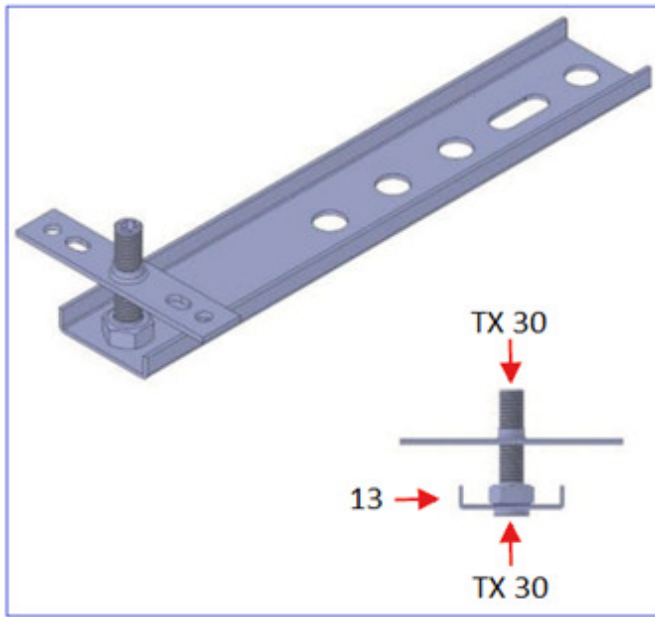

Article No.	Dimensions [mm]	PU
UF-H 150 S4	150x35x1,5 - 40mm	50
UF-H 150 S6	150x35x1,5 - 60mm	50
UF-H 150 M4	150x35x2,5 - 40mm	50
UF-H 150 M6	150x35x2,5 - 60mm	50
UF-H 200 S4	200x35x1,5 - 40mm	50
UF-H 200 S6	200x35x1,5 - 60mm	50
UF-H 200 M4	200x35x2,5 - 40mm	50
UF-H 200 M6	200x35x2,5 - 60mm	50
UF-H 250 M4	250x35x2,5 - 40mm	50
UF-H 250 M6	250x35x2,5 - 60mm	50
UF-H 250 L4	250x35x3,0 - 40mm	50
UF-H 250 L6	250x35x3,0 - 60mm	50
UF-H 300 L4	300x35x3,0 - 40mm	50
UF-H 300 L6	300x35x3,0 - 60mm	50
UF-H 350 L4	350x35x3,0 - 40mm	50
UF-H 350 L6	350x35x3,0 - 60mm	50



Article No.	Dimensions [mm]	PU
CC 10 W	Cover Cap Ø10,5 white	50
CC 10 B	Cover Cap Ø10,5 black	50

Suitable for all systems (aluminium, wood, plastic)

Window can be readjusted after plastering

Window mounting without visible dowel holes

Well-suited for fixed windows with glued in glazing

Blocking-free mounting

Maximum load tested by ift-Rosenheim

Suitable for fall-proof window mounting

Tested (ift-Rosenheim) for loads in the window layer: 11-003442-PR06, 14-002150-PR01, 18-003796-PR01							
1	Material thickness	Maximum load / bearing out A					
		30 mm	50 mm	70 mm	100 mm	130 mm	160 mm
	1,5 mm	136 kg	80 kg	44 kg			
	2,5 mm	175 kg	110 kg	58 kg	ca. 27 kg	ca. 14 kg	ca. 8 kg
	3,0 mm	ca. 208 kg	ca. 160 kg	114 kg	44 kg	27 kg	14 kg

Tested (ift-Rosenheim) for loads right angled to the window layer: 18-000650-PR01		
2	Gap e	maximum load
	20 mm	170 kg

Verified fall-proof window mounting.
ift-Rosenheim verification: 18-003796-PR07

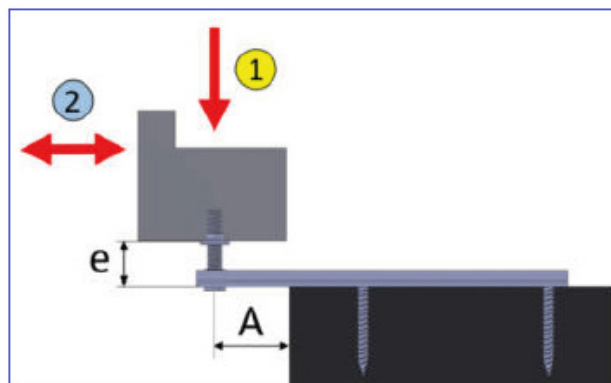

Installation instruction

Preparation: For window mounting with the UF-H Bracket, 10.0 mm holes must be pre-drilled into the window frame.

The bracket is placed in the drilled hole with the threaded pin and the connection plate is fixed to the window frame.

The window is placed into the window opening and adjusted. The window can also be readjusted after plastering by using a Torx 30 bit.

U-Float = U Floating Bracket

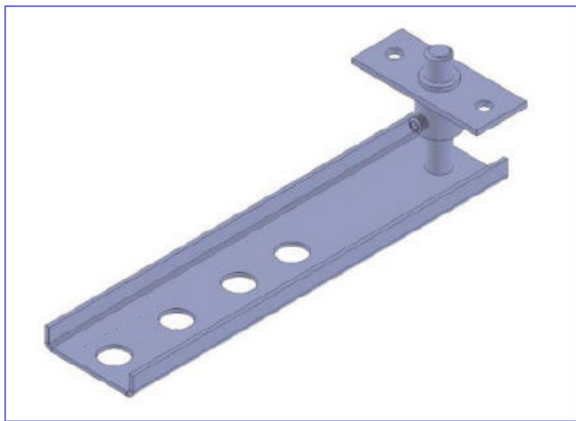

Article No.	Dimensions [mm]	PU
U-Float 150 S4-10	150x35x1,5 - 40mm sleeve 10	25
U-Float 150 S4-14	150x35x1,5 - 40mm sleeve 14	25
U-Float 200 S4-10	200x35x1,5 - 40mm sleeve 10	25
U-Float 200 S4-14	200x35x1,5 - 40mm sleeve 14	25
U-Float 200 M4-10	200x35x2,5 - 40mm sleeve 10	25
U-Float 200 M4-14	200x35x2,5 - 40mm sleeve 14	25
U-Float 250 M4-10	250x35x2,5 - 40mm sleeve 10	25
U-Float 250 M4-14	250x35x2,5 - 40mm sleeve 14	25
U-Float 300 L4-10	300x35x3,0 - 40mm sleeve 10	25
U-Float 300 L4-14	300x35x3,0 - 40mm sleeve 14	25
U-Float 350 L4-10	350x35x3,0 - 40mm sleeve 10	25
U-Float 350 L4-14	350x35x3,0 - 40mm sleeve 14	25
PU contain: 1 x U Bar + 1 x connection element with grub screw		

Suitable for all systems (aluminium, wood, plastic)

Window mounting without visible dowel holes

Well-suited for fixed windows with glued in glazing

Blocking-free mounting

Window mounting in accordance with resistance class RC2

Maximum load tested by ift-Rosenheim

Can also be used as a floating bearing

Tested (ift-Rosenheim) for loads in the window layer: 11-003442-PR06, 14-002150-PR01, 18-003796-PR01							
1	Material thickness	Maximum load / bearing out A					
		30 mm	50 mm	70 mm	100 mm	130 mm	160 mm
	1,5 mm	136 kg	80 kg	44 kg			
	2,5 mm	175 kg	110 kg	58 kg	ca. 27 kg	ca. 14 kg	ca. 8 kg
	3,0 mm	ca. 208 kg	ca. 160 kg	114 kg	44 kg	27 kg	14 kg

Installation instruction

For frame profiles with indentations, the 14 mm sleeve has to be selected in order that the grub screw can be reached. In case of profiles without indentations, the 10 mm sleeve will suffice.

Preparation: For window mounting with the U Floating Bracket, the frame has to be drilled out with 10.0 mm holes merely from behind. Therefore, the hole is not visible from inside.

The connection element is secured in such a way that the pin can be inserted into the frame hole.

Using the guide sleeve and the pin, the window can be infinitely adjusted. The wedging is possible via using the grub screw and it is RC2-certified.

UL-HL BR and UF-HL BR = UL and UF Heavy Load Bracket

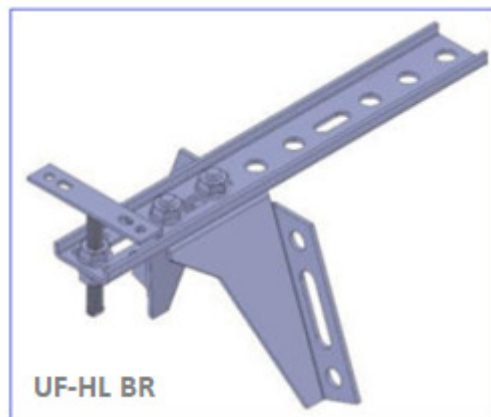
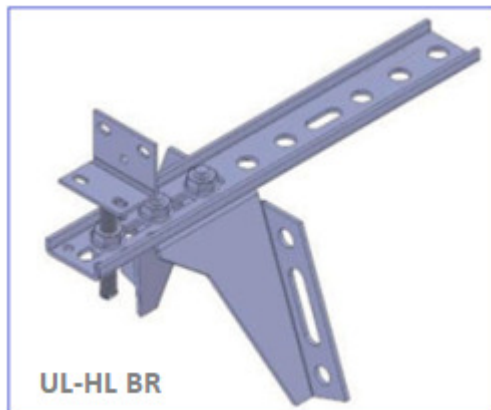

Article No.	Dimensions [mm]	PU
UF-HL BR 250 M	250x35x2,5 - support 65mm	25
UL-HL BR 250 M	250x35x2,5 - support 65mm	25
UF-HL BR 300 L	300x35x3,0 - support 110mm	25
UL-HL BR 300 L	300x35x3,0 - support 110mm	25
UF-HL BR 350 L	350x35x3,0 - support 155mm	25
UL-HL BR 350 L	350x35x3,0 - support 155mm	25
PU contain: 1 x U Bar + 1 x Adjusting Set (threaded pin with L-shape connection plate + 2 flange nuts M8) + 1 x W Mounting Anchor set (including 2 x carriage bolt M8x16; 2 x Flange nut M8)		

Secure window mounting for every masonry

Suitable for all systems (aluminium, wood, plastic)

Offers high load transference with great overhang

Blocking-free mounting

Maximum load tested by ift-Rosenheim

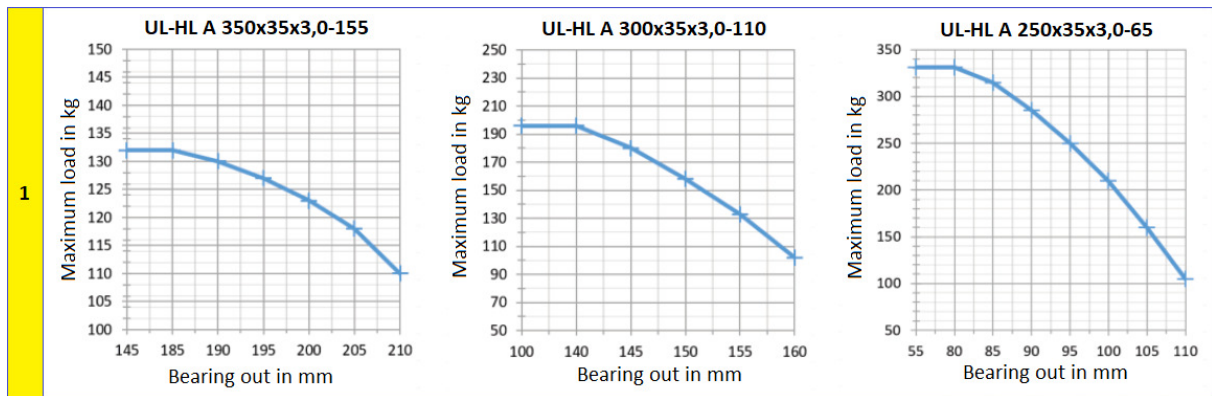

Tested (ift-Rosenheim) for loads in the window layer: 12-002151-PR09, 12-002151-PR10.

Because the support of the UL and UF Heavy Load Bracket does not always sit perfectly the position changes of up to 2.0 mm may occur when positioning the window. Therefore the load values are stated allowing for a 5.0 mm position change.

Tested (ift-Rosenheim) for loads right angled to the window layer: 12-002151-PR07		
2	Gap e	maximum load
	42 mm	68 kg

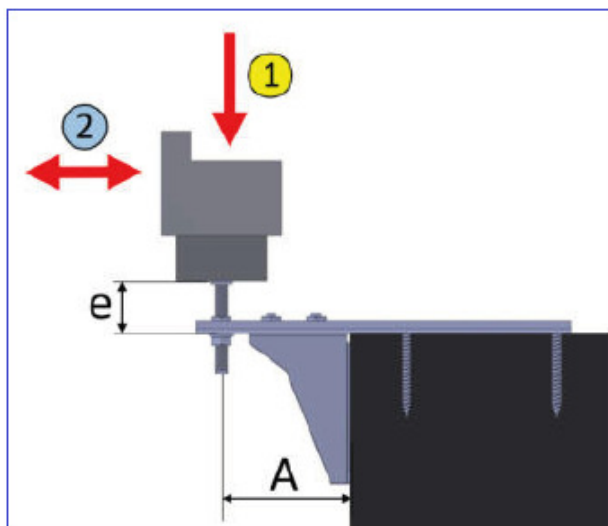

Installation instruction

Window mounting with the UL and UF Heavy Load Bracket is identical to that with the UL and UF Bracket, however the pillar allows us to reach a higher load transference. When mounting the UL and UF Heavy Load Bracket, only the U Bar must be fixed to the masonry. The pillar is merely pushed up to the masonry and screwed to the U Bar with two carriage bolts.

The pillar results in a moment of tilt at the U Bar. Therefore, in case of fixing to the hollow concrete block, a Brick Perforated Rail must be used to absorb the forces. For a smooth installation, we recommend a joint width 15-30 mm.

B-PR = Brick Perforated Rail



Article No.	Dimensions [mm]	PU
B-PR 160	15x160x2,0	100
B-PR 200	15x200x2,0	100

For secure mounting on the vertically perforated brick

Tested by ift-Rosenheim

Installation instruction



Drill a $\varnothing 10$ mm hole at least 80 mm beneath the anchor. Then insert the Brick Perforated Rail using the hammer.

Screw the $\varnothing 7.5$ mm Window Frame Screws through the anchor from above into the Brick Perforated Rail and tighten it.

CAUTION!

In case of a masonry where top stone is not connected to the soffit and therefore cannot be loaded with leverage forces, the Brick Perforated Rail is inserted into the stone below and screwed with a long $\varnothing 7.5$ mm Window Frame Screw.

B-ST = Brick Static Tube

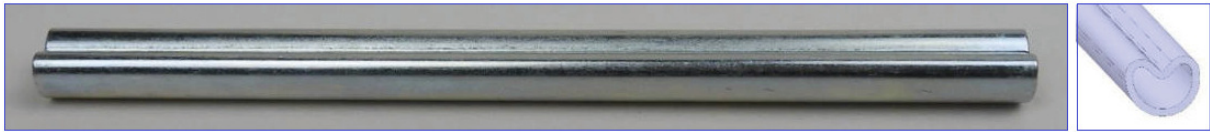

For secure window mounting on the vertically perforated brick with big chambers.

Article No.	Dimensions [mm]	PU
B-ST 160	15x200x1,5	50

SA = Secure Angle

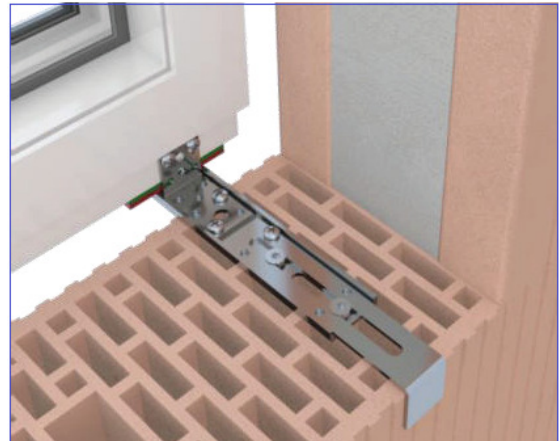
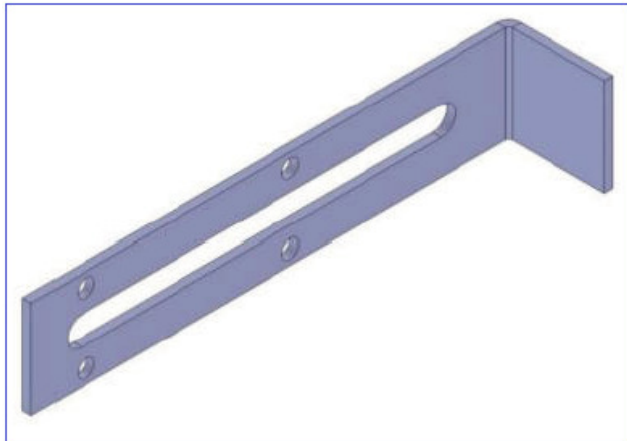

Article No.	Dimensions [mm]	PU
SA 140x30 M	140x30x2,5	50
PU contain: 1 x Secure Angle + 2 x drilling screw $\varnothing 4,8 \times 13$ + 2 x Fischer dowel SX 10x50 + 2 x Window Frame screw $\varnothing 7.5 \times 42$		

Secure Angle is tested (ift-Rosenheim) according to ETB-Guidelines: 17-000719-PR03

Developed for the fall protection with perforated bricks

Tested with a 17.5 mm stone and is transferable to all thicker perforated blocks

Tested by ift-Rosenheim

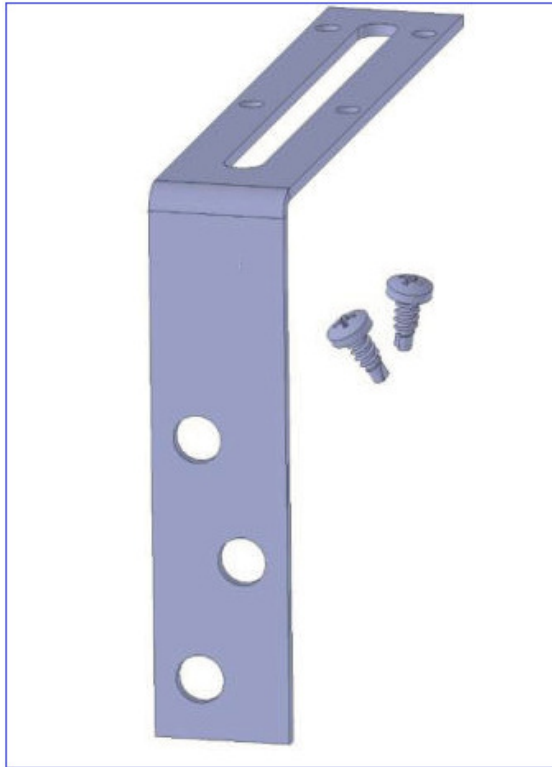

Article No.	Dimensions [mm]	PU
SA 140x115 M	140x115x2,5	50
SA 140x250 M	140x250x2,5	50
PU contain: 1 x Secure Angle + 2 x drilling screw $\varnothing 4,8 \times 13$		

Installation instruction

For anchor mounting, the Secure Angle is screwed to the anchor with at least two Drilling Screws and fixed with two dowels to the side of the masonry.

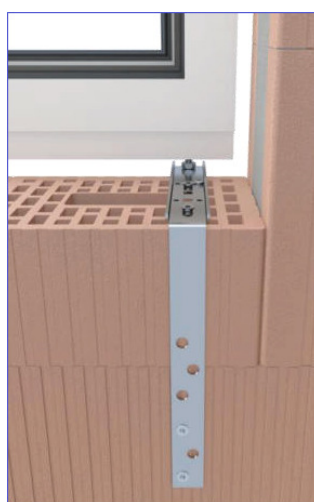

CAUTION!

If the top stone of a masonry is not connected to the soffit and therefore cannot be loaded with leverage forces, the large Secure Angle should be used to mount it to the stone below.

F-A and U-A = Flat and U Angle (in combination with other products)

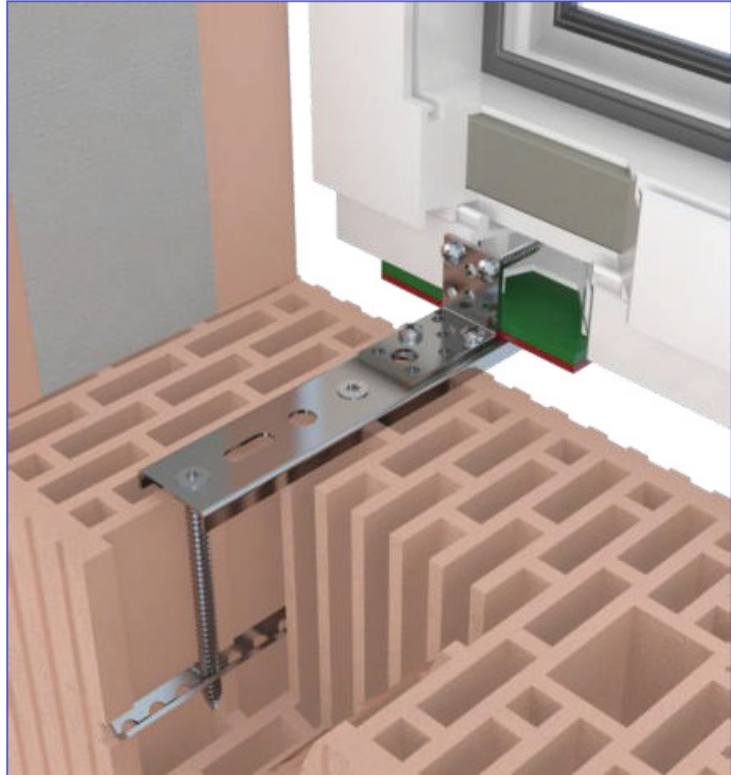
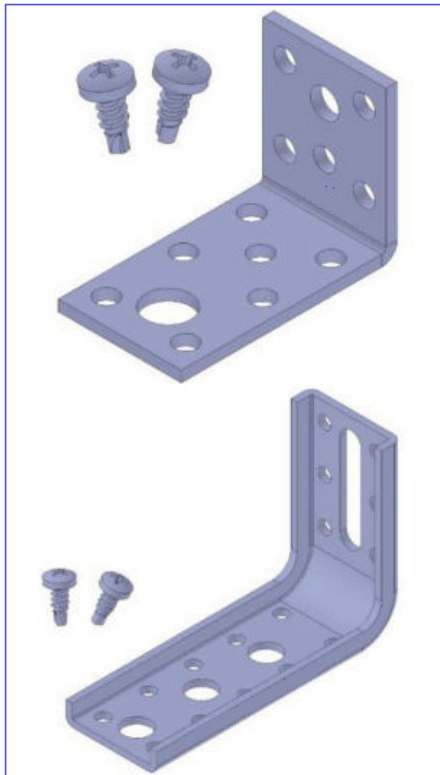

Article No.	Dimensions [mm]	PU
F-A 35x50 M	35x50x2,5 (flat steel)	50
U-A 65x95 M	65x95x2,5	50
U-A 65x145 M	65x145x2,5	50
U-A 65x170 M	65x170x2,5	50
U-A 95x140 L	95x140x3,0	50
U-A 110x125 L	110x125x3,0	50
U-A 110x150 L	110x150x3,0	50
PU contain: 1 x F or U Angle + 2 x drilling screw Ø4,8x13		

For the connection of window and mounting anchor

For the bracing of balcony connection profiles

Suitable for fall-proof window mounting

Tested (ift-Rosenheim) for loads in the window layer: 11-003442-PR06, 14-002150-PR01, 18-003796-PR01							
1	Material thickness	Maximum load / bearing out A					
		30 mm	50 mm	70 mm	100 mm	130 mm	160 mm
	1,5 mm	136 kg	80 kg	44 kg			
	2,5 mm	175 kg	110 kg	58 kg	ca. 27 kg	ca. 14 kg	ca. 8 kg
	3,0 mm	ca. 208 kg	ca. 160 kg	114 kg	44 kg	27 kg	14 kg

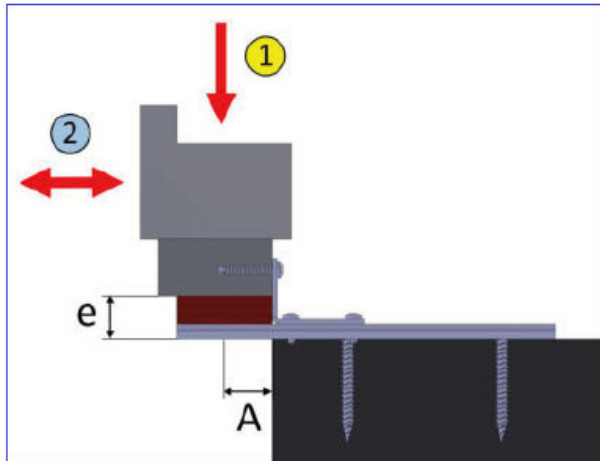

F-A 35x50 M (35x50x2,5mm)

Tested (ift-Rosenheim) for loads right angled to the window layer: 18-000650-PR01

	Gap e	maximum load
2	13 mm	139 kg

WU-A = Wall U Angle

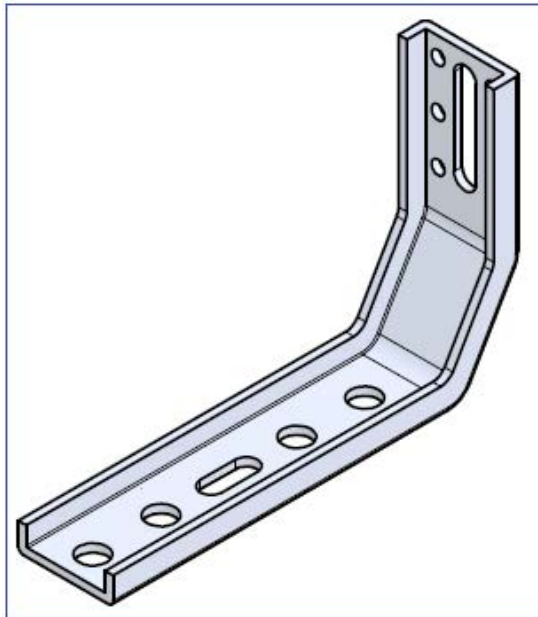
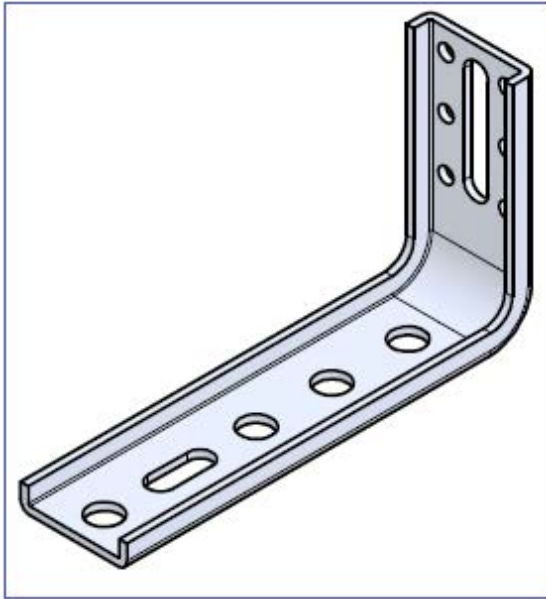

Article No.	Dimensions [mm]	PU
WU-A 50x140 S	50x140x1,5	50
WU-A 65x125 S	65x125x1,5	50
WU-A 65x145 S	65x145x1,5	50
WU-A 65x145 M	65x145x2,5	50
WU-A 65x145 L	65x145x3,0	50
WU-A 65x170 M	65x170x2,5	50
WU-A 75x135 M	75x135x2,5	50
WU-A 95x140 L	95x140x3,0	50
WU-A 150x160 L	150x160x3,0	50
WU-A 95x150 L - 2	95x150x3,0 (two level tilt)	50

Tested (ift-Rosenheim) for load transference according to ETB-Guidelines: 17-000719-PR02, 18-000732-PR02

Article No.	Dimensions [mm]	PU
WU-A 65x145 L-DS32	65x145x3,0 - Aluminium and PVC system (Set with Drilling Screws L=32 mm & dowels)	50
WU-A 65x145 L-DS50	65x145x3,0 - Aluminium and PVC system (Set with Drilling Screws L=50 mm & dowels)	50
WU-A 80x180 L-DS52	65x145x3,0 - Wood system (Set with Drilling Screws L=52 mm & dowels)	50

Tested (ift-Rosenheim) for loads in the window layer: 11-003442-PR06, 12-002151-PR04, 14-002150-PR02, 17-001190-PR01

1	Material thickness	Maximum load / bearing out A						
		25 mm	35 mm	40 mm	55 mm	57 mm	60 mm	87 mm
	1,5 mm	212 kg	ca. 110 kg	45 kg	ca. 40 kg	38 kg		
	2,5 mm	min 212 kg	170 kg	ca. 140 kg	ca. 68 kg	ca. 60 kg	ca. 50 kg	34 kg
	3,0 mm	min 347 kg	347 kg	ca. 270 kg	147 kg	ca. 143 kg	139 kg	66 kg

Simple and fast mounting of windows inside the insulating layer

Suitable for all systems (aluminium, wood, plastic)

Short leg for mounting to the window frame, long leg for mounting to the masonry

Two-level tilt for more leeway for the sealing

Window mounting in accordance with resistance class RC2

Suitable for fall-proof window mounting

Maximum load tested by ift-Rosenheim

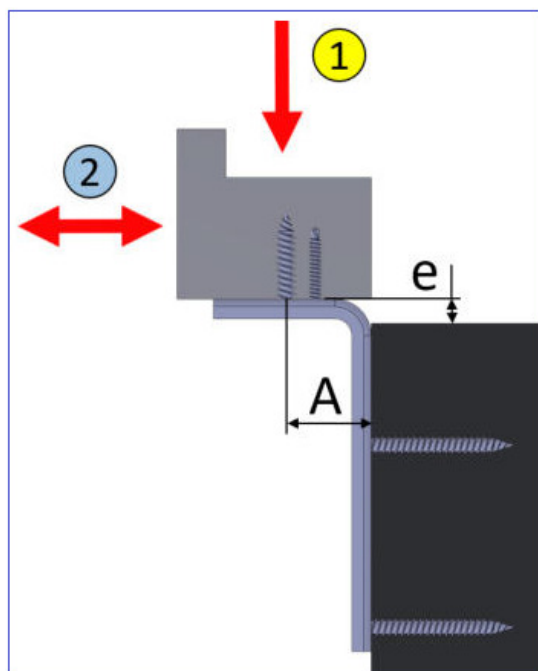

Tested (ift-Rosenheim) for loads right angled to the window layer: 18-000650-PR01

2	Material thickness	Maximum load
	1,5 mm	59 kg
	2,5 mm	91 kg
	3,0 mm	182 kg

Installation instruction

The Wall U Angle (WU-A) is first screwed to the window frame through the slotted hole using a $\text{Ø}7.5 \times 42$ mm Window Frame Screw.

The frame is placed on the bottom amount or on the Window Mounting Clamps and the height is aligned.

The window WU Angle is fixed to the masonry.

The fine adjustment of the depth is realised via the slotted hole. To secure the configuration, the screw is tightened to the window and fixed with additional screws through the holes.

WUL-A and WUF-A = Wall U Angle Adjustable

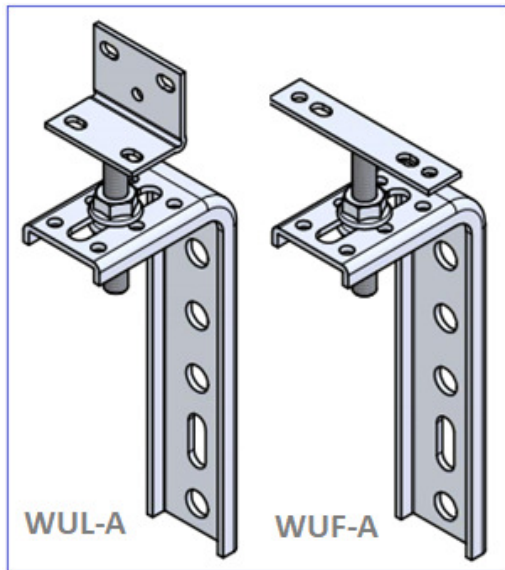

Article No.	Dimensions [mm]	PU
WUF-A 65x145 M	65x145x2,5	50
WUF-A 95x140 L	95x140x3,0	50
WUL-A 65x145 M	65x145x2,5	50
WUL-A 95x140 L	95x140x3,0	50
PU contain: 1 x WU Angle + 1 x Adjusting Set (60mm threaded pin with FLAT connection plate + 2 flange nuts M8)		

Simple and fast mounting of windows inside the insulating layer

With angle connection, suitable for mounting from below

With flat connection, suitable for mounting from below and at the side

Suitable for all systems (aluminium, wood, plastic)

The angles are adjustable in three dimensions in order to be able to compensate structural tolerances

Blocking-free mounting

Maximum load tested by ift-Rosenheim

Tested (ift-Rosenheim) for loads in the window layer: 11-003442-PR06, 12-002151-PR04, 14-002150-PR02, 17-001190-PR01								
1	Material thickness	Maximum load / bearing out A						
		25 mm	35 mm	40 mm	55 mm	57 mm	60 mm	87 mm
	1,5 mm	212 kg	ca. 110 kg	45 kg	ca. 40 kg	38 kg		
	2,5 mm	min 212 kg	170 kg	ca. 140 kg	ca. 68 kg	ca. 60 kg	ca. 50 kg	34 kg
	3,0 mm	min 347 kg	347 kg	ca. 270 kg	147 kg	ca. 143 kg	139 kg	66 kg

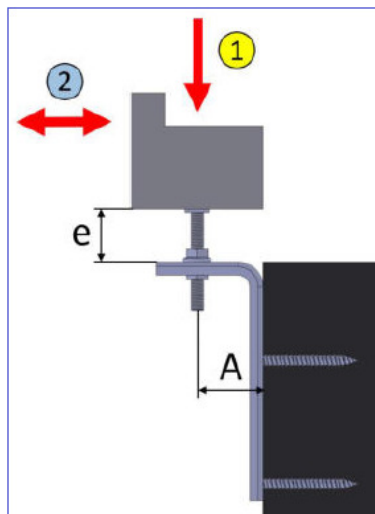

Tested (ift-Rosenheim) for loads right angled to the window layer: 12-002151-PR07		
2	Gap e	maximum load
	36 mm	68 kg

Installation instruction

Window mounting from below

The angles are fixed to the masonry.

The window is positioned on the adjusting elements, laterally adjusted and the flat or angle connection is screwed to the window frame / window sill connection profile.

The window is readjusted and fixed using the screw connection in the slotted hole.

Lateral window mounting

The adjusting element is fixed to the window frame.

The first nut is screwed all the way in (toward the window), the angle is positioned with the slotted hole at the adjusting element and secured with the second nut.

The angle is fixed to the masonry with at least two dowels. The lateral and depth adjustment are realised using the screw connection in the slotted hole.

WU-Float = Floating Angle

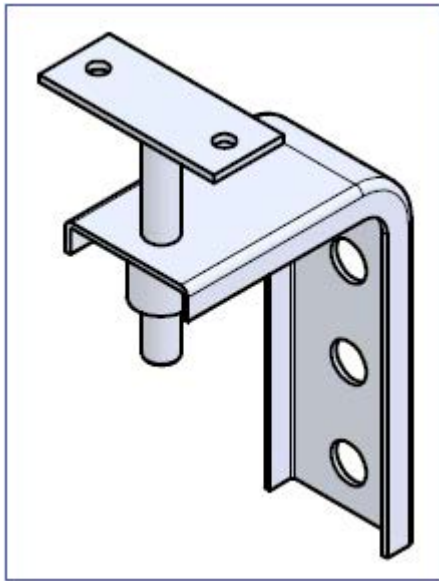

Article No.	Dimensions [mm]	PU
WU-Float 65x95 S	65x95x1,5	25
PU contain: 1 x WU Angle with sleeve + 1 x connection element		

Installation instruction

First the angle is secured to the masonry.

The mounting plate is fixed to the window frame. For the upward extension, we recommend a distance of 5-25 mm between the window mounting angle and the window frame.

DU-A and FBU-A = Double U Angle and Flat Bar U Angle

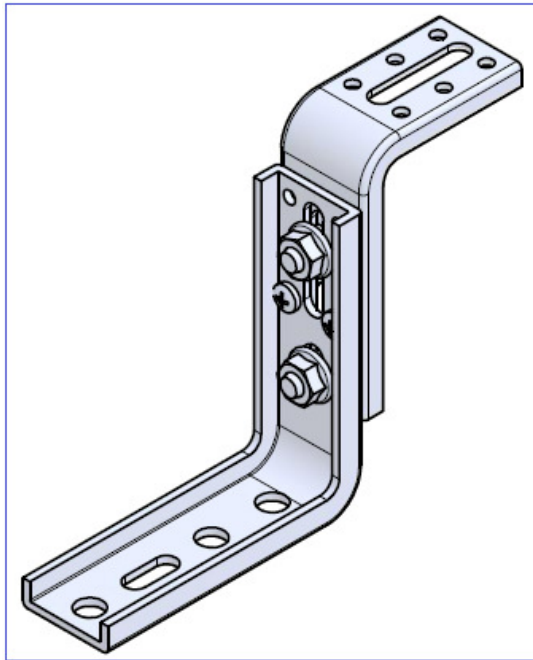

Article No.	Dimensions [mm]	PU
DU-A 105x105+65x95	WU-A 105x105x3,0 + WU-A 65x95x2,5 2 flange nuts M8 + 2 carriage bolts M8x16 + 2 drilling screw \varnothing 4,8x13 (adjustment vertically 105-155mm, horizontal areas 105 and 65mm)	10
DU-A 130x135+65x145	WU-A 130x135x3,0 + WU-A 65x145x2,5 2 flange nuts M8 + 2 carriage bolts M8x16 + 2 drilling screw \varnothing 4,8x13 (adjustment vertically 145-230mm, horizontal areas 135 and 65mm)	10

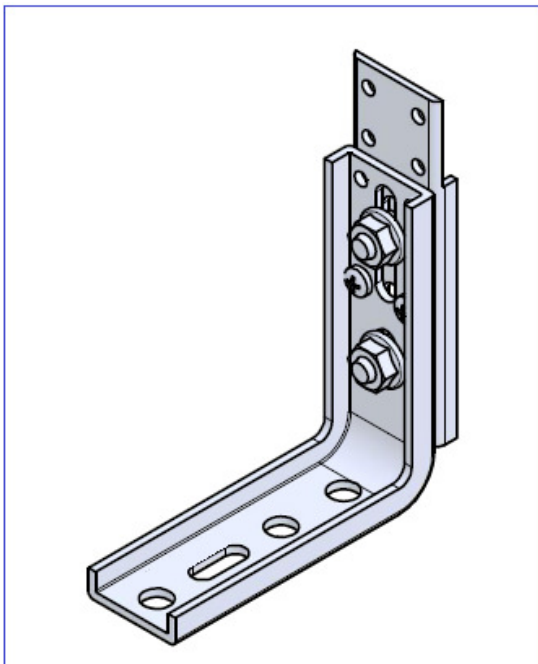

Article No.	Dimensions [mm]	PU
FBU-A 105x105+120	WU-A 105x105x3,0 + U-Bar 120x2,5 2 flange nuts M8 + 2 carriage bolts M8x16 + 2 drilling screw \varnothing 4,8x13 (adjustment vertically 120-185mm, horizontal area 105mm)	10
FBU-A 135x130+150	WU-A 130x135x3,0 + U-Bar 150x2,5 2 flange nuts M8 + 2 carriage bolts M8x16 + 2 drilling screw \varnothing 4,8x13 (adjustment vertically 150-225mm, horizontal area 135mm)	10

WL-MBR and WF-MBR = Wall Mounting Bracket

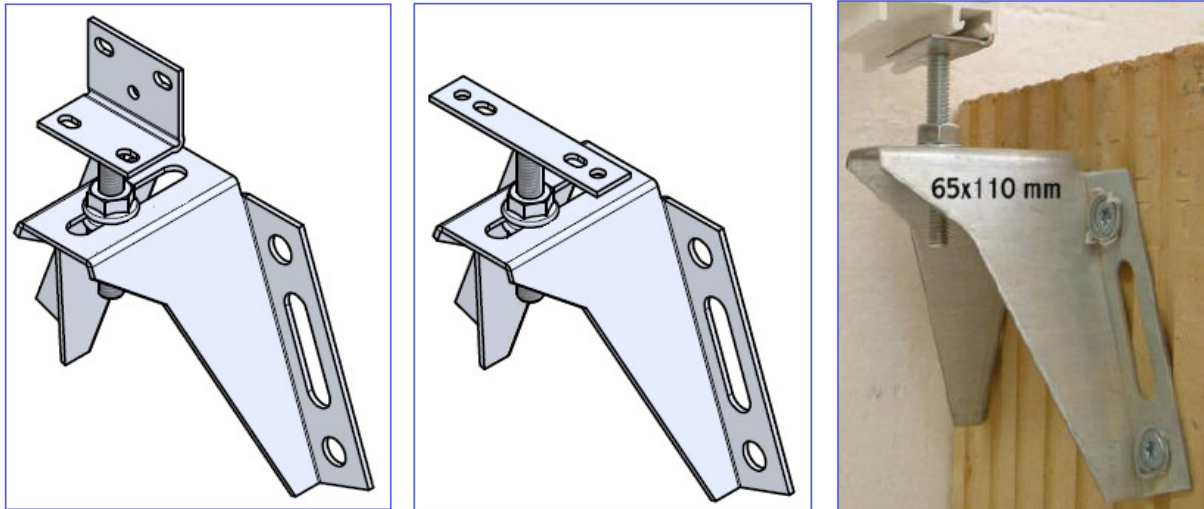

Tested (ift-Rosenheim) for loads in the window layer: 11-003442-PR06					
	Article No.	Dimensions [mm]	Bearing out A	Maximum load	PU
1	WF-MBR 65x110 M	65x110x2,5	55 mm	237 kg	50
	WL-MBR 65x110 M	65x110x2,5	55 mm	237 kg	50
	WF-MBR 110x110 M	110x110x2,5	105 mm	99 kg	50
	WL-MBR 110x110 M	110x110x2,5	105 mm	99 kg	50
PU contain: 1 x W Mounting Angle + 1 x Adjusting Set (60mm threaded pin with connection plate + 2 flange nuts M8)					

Simple and fast mounting of windows inside the insulating layer

Suitable for all systems (aluminium, wood, plastic)

Blocking-free mounting

With angle connection, suitable for mounting from below

With flat connection, suitable for mounting from below and lateral

The mounting bracket is adjustable in three dimensions in order to be able to compensate structural tolerances

Maximum load tested by ift-Rosenheim

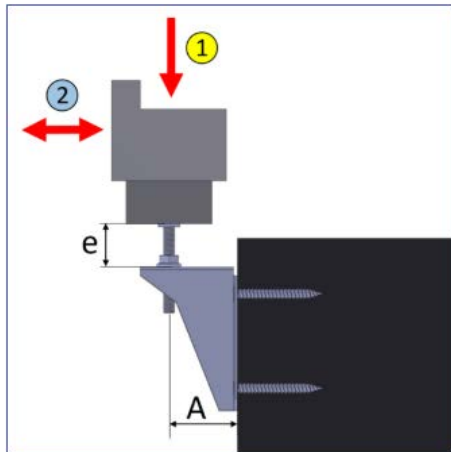

Tested (ift-Rosenheim) for loads right angled to the window layer: 12-002151-PR07		
	Gap e	maximum load
2	36 mm	68 kg

Installation instruction

Window mounting from below

The Wall Mounting Brackets are fixed to the masonry.

The window is positioned on the adjusting elements, laterally adjusted and the flat or angle connection is screwed to the window frame / window sill connection profile.

The window is readjusted and fixed using the screw connection in the slotted hole.

Lateral window mounting

The adjusting element is fixed to the window frame.

The first nut is screwed all the way in (toward the window), the Wall Mounting Bracket is positioned with the slotted hole at the adjusting element and secured with the second nut.

The Wall Mounting Bracket is fixed to the masonry with at least two dowels. The lateral and depth adjustment are realised using the screw connection in the slotted hole.

FR-HL A = Frame Heavy Load Angle

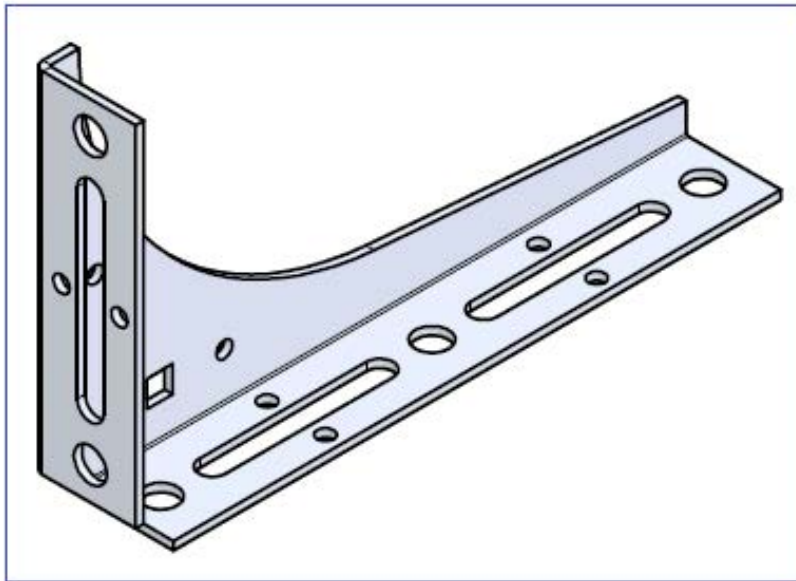

Tested (ift-Rosenheim) for loads in the window layer: 17-001190-PR01					
	Article No.	Dimensions [mm]	Bearing out A	Maximum load	PU
1	FR-HL A 60x180 M	60x180x2,5	35 mm	213 kg	10
	FR-HL A 95x180 M	95x180x2,5	70 mm	213 kg	10
	FR-HL A 120x200 M	120x200x2,5	110 mm	172 kg	10
	FR-HL A 110x150 M	110x150x2,5	70 mm	213 kg	10
	FR-HL A 150x200 M	150x200x2,5	110 mm	172 kg	10
	FR-HL A 180x200 M	180x200x2,5	150 mm	301 kg	10
	FR-HL A 200x250 M	200x250x2,5	150 mm	301 kg	10
			200 mm	157 kg	
	FR-HL C 200x300 M	200x300x2,5	150 mm	301 kg	10
			200 mm	157 kg	

Simple and fast mounting of windows in the insulation layer

Insulation is easy to install afterwards

Suitable for all systems (aluminium, wood, plastic)

High load transference

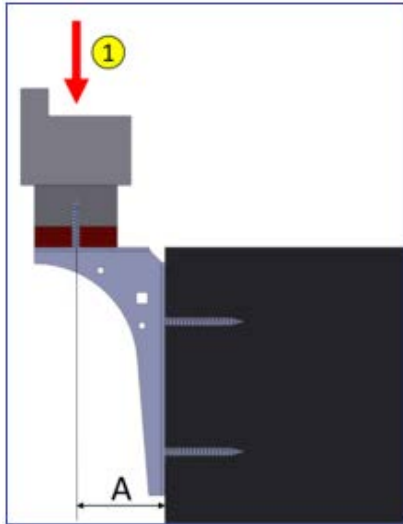

Installation instruction

Frame Heavy Load Angles are fixed to the masonry. Then the window is placed onto the angle, aligned and laterally adjusted.

The screw connection is attached from below using a $\varnothing 7.5$ mm Window Frame Screw through the angle and the wedging into the window frame.

J-HL BR = Joist Heavy Load Bracket

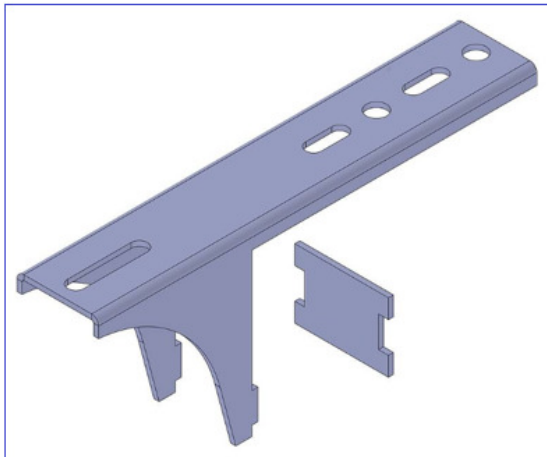

Article No.	Dimensions [mm]	Length (mm)	Bearing out L1	PU
J-HL BR 220 M	220x2,5_80	220	80	25
J-HL BR 265 M	265x2,5_125	265	125	25
J-HL BR 315 M	315x2,5_175	315	175	25
J-HL BR 365 M	365x2,5_225	365	225	25
PU contain: 1 x J-HL Bracket + 1 x protection plate				

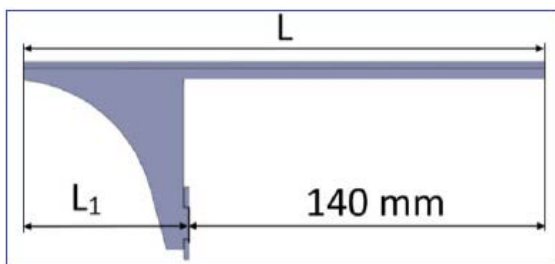

Suitable for all systems (aluminium, wood, plastic)

Offers high load transference with great overhang

Inclusive Protection Plate protects the masonry and distributes point load on area load

Protects the seal

Maximum load tested by ift-Rosenheim

Many possible combinations with other K-Universal anchors

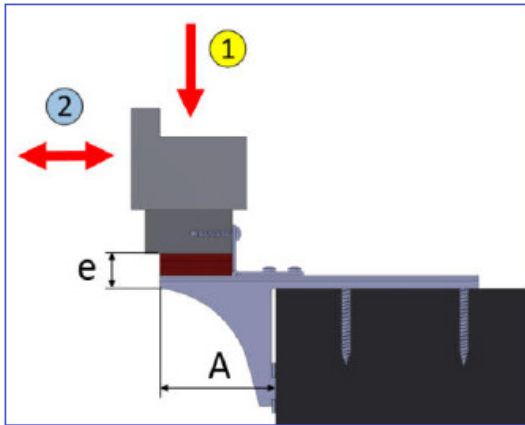

Tested (ift-Rosenheim) for loads in the window layer: 17-001190-PR01		
	Bearing out A	Maximum load
1	70 mm	435 kg
	110 mm	375 kg
	145 mm	342 kg

Tested (ift-Rosenheim) for loads right-angled to the window layer: 18-000650-PR01				
	Article No.	Dimensions	Gape e	Max. load
2	F-A 35x50 M	35x50x2,5	14 mm	139 kg

Installation instruction

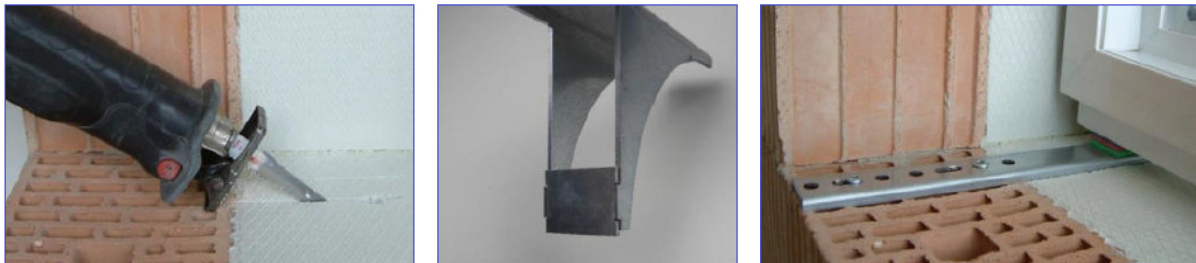

Cut clear the mounting position at insulation area.

Insert Protection Plate. It protects soft stones and seals from damage.

Mount the Joist Heavy Load Bracket to the insulation. Bridges has to be fit closely to the masonry.

Samples in combination with other products for window installation

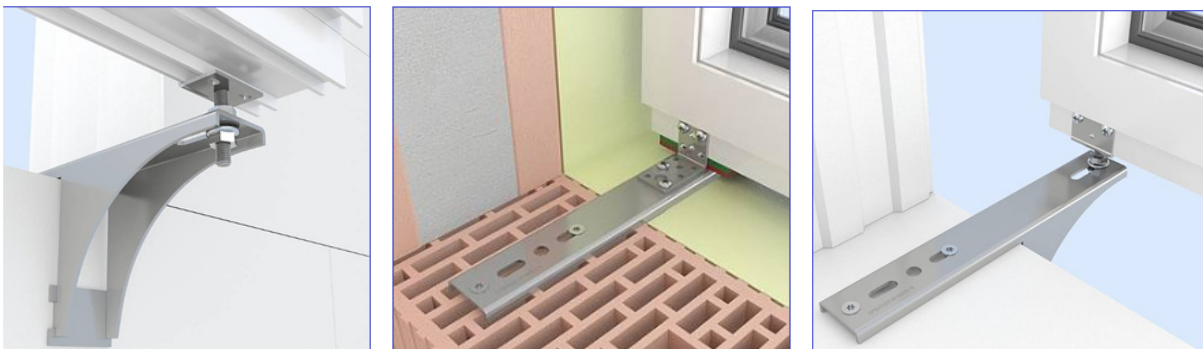

J-HL BR-UA = Joist Heavy Load Bracket with Angle for base profile

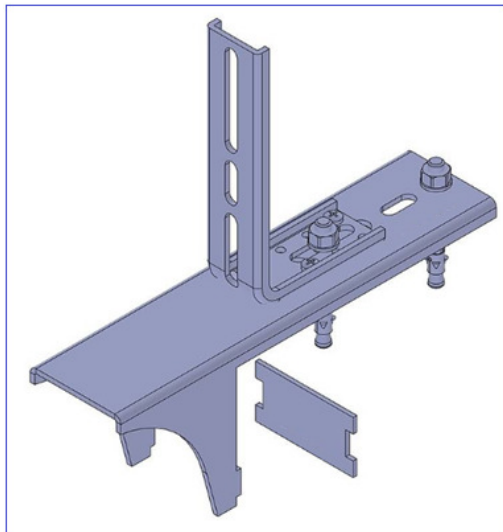

Article No.	Dimensions [mm]	Length (mm)	Bearing out L1	PU
J-HL BR-UA 250 M	250x2,5_80	250	80	5
J-HL BR-UA 300 M	300x2,5_125	300	125	5
J-HL BR-UA 350 M	350x2,5_175	350	175	5
J-HL BR-UA 400 M	400x2,5_225	400	225	5
PU contain: 1 x J-HL Bracket + 1 x protection plate + WU Angle 65x145x2,5 + 2 x drilling screw $\varnothing 4,8 \times 13$ + 2 x Heavy-duty dowel $\varnothing 8 \times 71$				

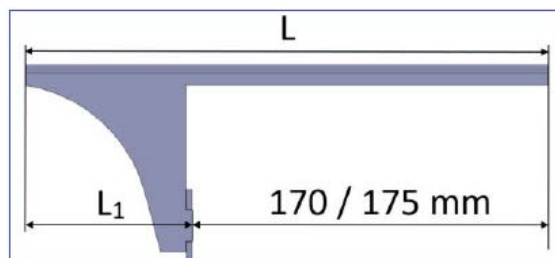

For mounting underneath floor-to-ceiling elements, in particular for lift-up sliding doors

Simple and fast mounting in case of an already existing insulating layer

Offers high load transference

Secure fixing of the window to the concrete floor

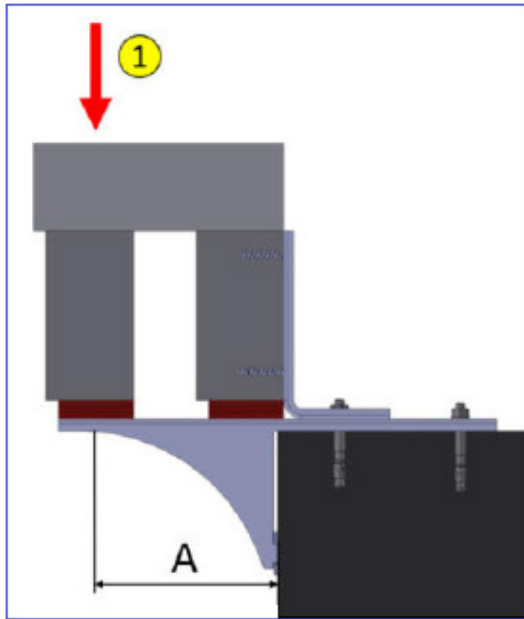

Tested (ift-Rosenheim) for loads in the window layer: 17-001190-PRO1, 18-003796-PRO1		
	Bearing out A	Maximum load
1	50 mm	622 kg
	95 mm	622 kg
	145 mm	551 kg
	195 mm	284 kg

Installation instruction

Cut clear the mounting position at insulation area.

Insert Protection Plate. It protects soft stones and seals from damage.

Mount the Joist Heavy Load Bracket to the insulation. The bridges with the protection plate have to be aligned with the concrete floor. Secure it with the first Heavy-Duty Dowel.

Place second Heavy-Duty Dowel. Screw connecting element to door element and console.

BP-BR = Base Profile Bracket

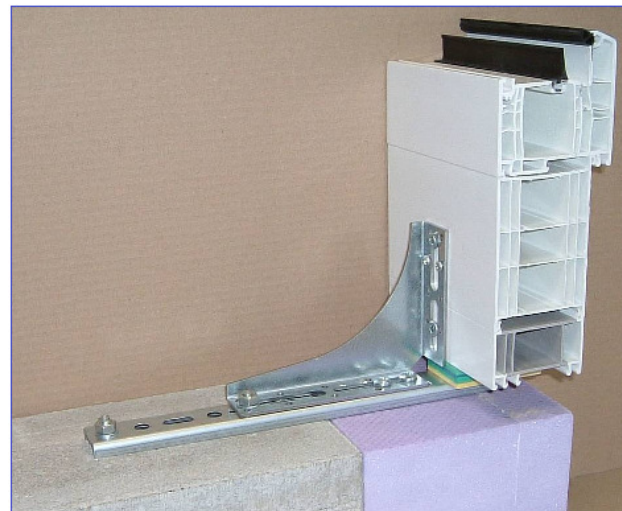
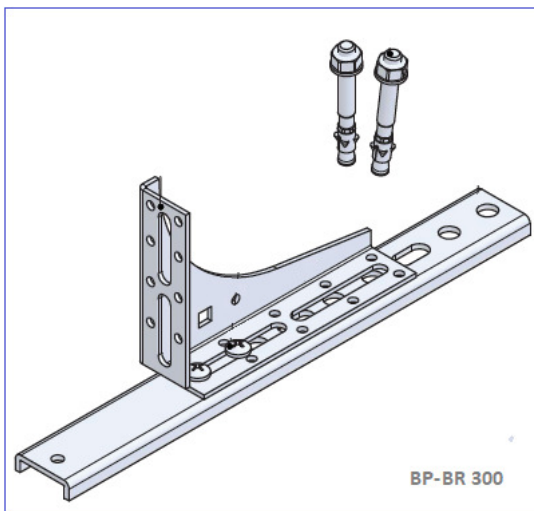
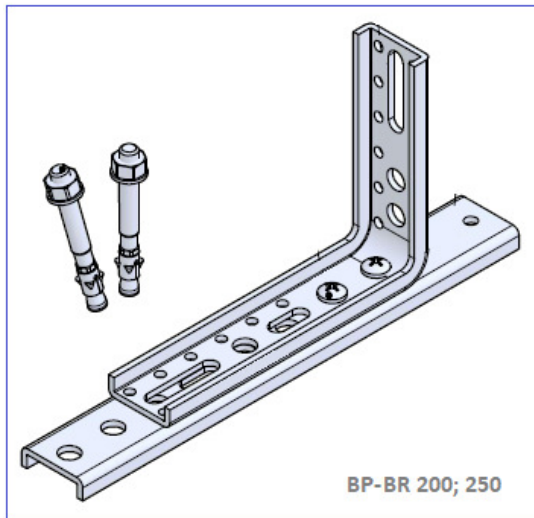

Tested (ift-Rosenheim) for loads in the window layer: 17-001190-PR01

	Article No.	Dimensions [mm]	Bearing out A	Maximum load	PU
1	BP-BR 200 L	200x35x3,0_110x125	70 mm	123 kg	25
	BP-BR 250 L	250x35x3,0_110x150	90 mm	144 kg	25
	BP-BR 300 L	300x35x3,0_110x150	110 mm	116 kg	25
PU contain: 1 x UB-HL + WU Angle + 2 x drilling screw Ø6,3x16 + 2 x Heavy-duty dowel Ø8x71					

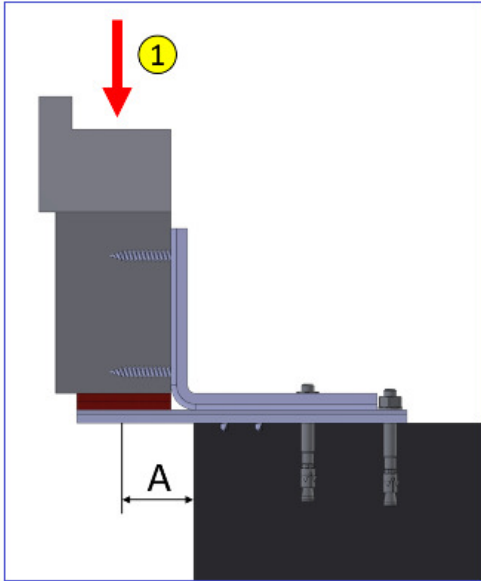

- For secure mounting underneath floor-depth elements
- Right-angled bracing of the balcony connection profile
- Offers high load transference
- Simple and fast mounting in case of an already existing insulating layer
- Maximum load tested by ift-Rosenheim
- Suitable for fall-proof window mounting

Installation instruction



The U-Bar is fixed to the concrete floor using a Heavy-Duty Dowel .

The construction is placed onto the U-Bar and aligned using mounting blocks. For a high load transference and in order to mount the base profile, a U-Angle or Frame Heavy Load Angle is used for minor overhang.

The angle is screwed to the U-Bar using two Drilling Screws. The screws must be positioned as closely as possible to the base profile in order that maximum load can be carried. The angle and the U-Bar are fixed with second Heavy-Duty Dowel to the concrete floor.

BP-HLA = Base Profile Heavy Load Angle

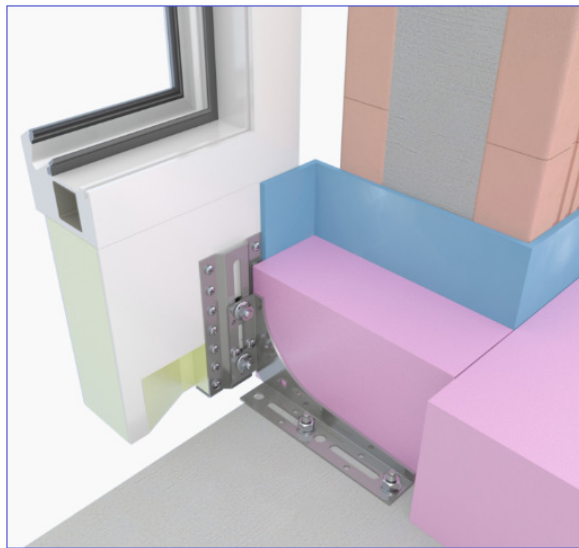
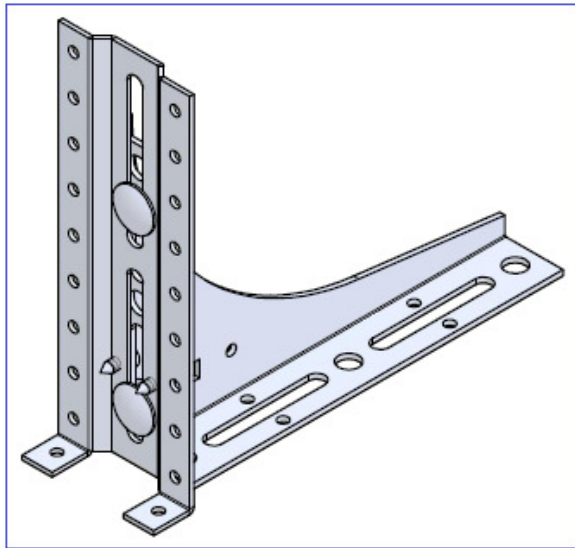

Article No.	Dimensions [mm]	PU
BP-HLA 60 M	h60_60x180x2,5 (adjustment -25...35mm)	5
BP-HLA 100 M	h100_95x180x2,5 (adjustment -40...45mm)	5
BP-HLA 140 M	h140_95x180x2,5 (adjustment -80...45mm)	5
BP-HLA 180 M	h180_150x20x2,5 (adjustment -115...100mm)	5
BP-HLA 220 M	h220_150x200x2,5 (adjustment -160...100mm)	5
PU contain: 1 x FR-HL Angle + 1 x BP fixing plate + 2 x drilling screw $\varnothing 4,8 \times 13$ + 1 or 2 carriage bolt M8x16 + 1 or 2 flange nuts M8		

For the mounting of floor-depth elements

Offers high load transference

Secure fixing of the window to the concrete floor

Secure wedging even in case of unreinforced connection profiles

Installation instruction

The fixing plate has an installation edge and multiple drilled holes for a secure mounting even to unreinforced connection profiles. The Heavy Load Frame Angle is screwed to the connection plate with the carriage bolts and fixed with two drilling screws. For a secure mounting, the angle must be fixed to the concrete floor with at least two heavy-duty dowels.

F-AS, L-AS and HBP-AS = Flat shape, L shape and Hidden Base Profile Adjusting Set

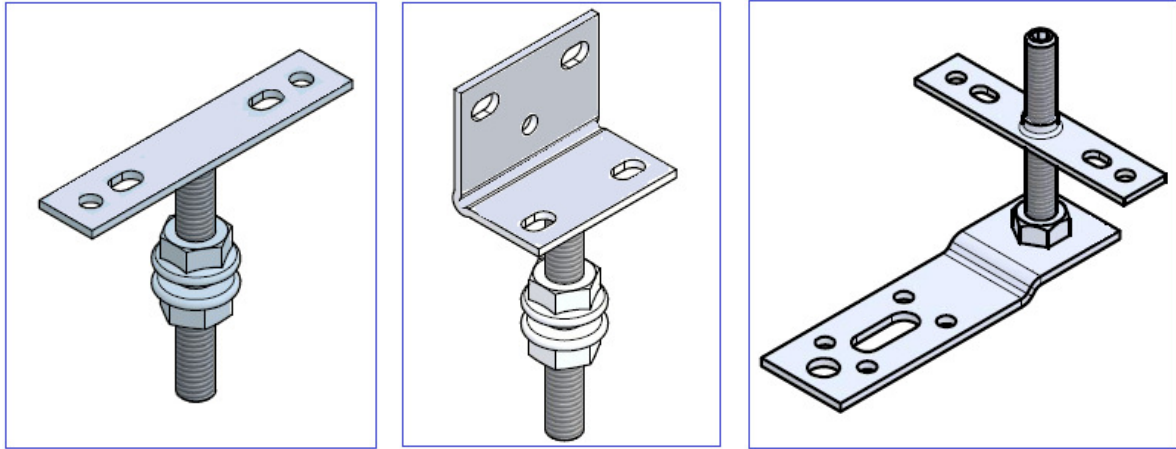

Article No.	Dimensions [mm]	PU
F-AS 40	M8x40mm (flat plate)	50
F-AS 60	M8x60mm (flat plate)	50
L-AS 40	M8x40mm (L shape plate)	50
L-AS 60	M8x40mm (L shape plate)	50
HBP-AS 40	100x28x2,5_M8x40mm (flat plate)	50
HBP-AS 60	100x28x2,5_M8x60mm (flat plate)	50
HBP-AS 70	100x28x2,5_M12x70mm (flat plate)	50

Simple and fast mounting of windows into the isolation layer

Suitable for all systems (aluminium, wood, plastic)

Easy alignment and wedging

HBP-AS may be adjusted from above, below and from the side

HBP-AS may be combined with the U-Bar and Joist Heavy Load Bracket

Fasteners

Concrete Frame Screw, Countersunk head

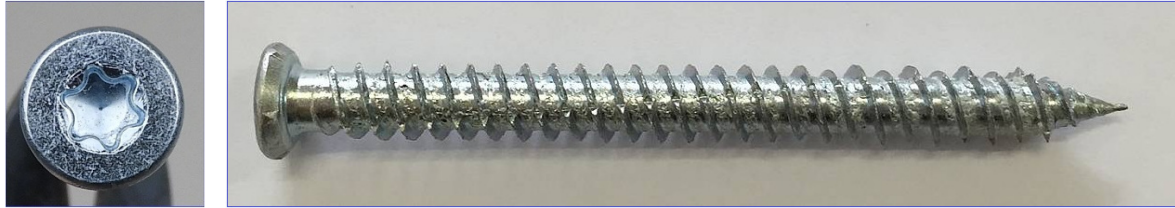

Article No.	Dimensions [mm]	PU
7,5x42 CSH	7,5x42mm Countersunk Head	100
7,5x52 CSH	7,5x52mm Countersunk Head	100
7,5x62 CSH	7,5x62mm Countersunk Head	100
7,5x72 CSH	7,5x72mm Countersunk Head	100
7,5x82 CSH	7,5x82mm Countersunk Head	100
7,5x92 CSH	7,5x92mm Countersunk Head	100
7,5x102 CSH	7,5x102mm Countersunk Head	100
7,5x112 CSH	7,5x112mm Countersunk Head	100
7,5x122 CSH	7,5x122mm Countersunk Head	100
7,5x132 CSH	7,5x132mm Countersunk Head	100
7,5x152 CSH	7,5x152mm Countersunk Head	100
7,5x182 CSH	7,5x182mm Countersunk Head	100

Concrete Frame Screw, Fillister head



Article No.	Dimensions [mm]	PU
7,5x72 FH	7,5x72mm Fillister Head	100
7,5x82 FH	7,5x82mm Fillister Head	100
7,5x92 FH	7,5x92mm Fillister Head	100
7,5x112 FH	7,5x112mm Fillister Head	100
7,5x132 FH	7,5x132mm Fillister Head	100
7,5x152 FH	7,5x152mm Fillister Head	100
7,5x182 FH	7,5x182mm Fillister Head	100

Concrete Frame Screw, Cylinder head



Article No.	Dimensions [mm]	PU
7,5x72 CYLH	7,5x72mm Cylinder Head	100
7,5x82 CYLH	7,5x82mm Cylinder Head	100
7,5x92 CYLH	7,5x92mm Cylinder Head	100
7,5x102 CYLH	7,5x102mm Cylinder Head	100
7,5x112 CYLH	7,5x112mm Cylinder Head	100
7,5x122 CYLH	7,5x122mm Cylinder Head	100
7,5x132 CYLH	7,5x132mm Cylinder Head	100
7,5x152 CYLH	7,5x152mm Cylinder Head	100
7,5x182 CYLH	7,5x182mm Cylinder Head	100

Drilling Screw, ISO 15481

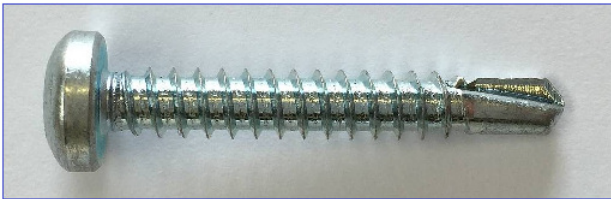

Article No.	Dimensions [mm]	PU
4,8x13 DRS	4,8x13mm Drilling Screw	500
4,8x32 DRS	4,8x32mm Drilling Screw	500
4,8x50 DRS	4,8x50mm Drilling Screw	500
4,8x70 DRS	4,8x70mm Drilling Screw	500
6,3x16 DRS	6,3x16mm Drilling Screw	500
6,3x32 DRS	6,3x32mm Drilling Screw	500
6,3x50 DRS	6,3x50mm Drilling Screw	500
6,3x70 DRS	6,3x70mm Drilling Screw	250

Fischer Dowel SX (for 7,5 mm Concrete Frame Screw)

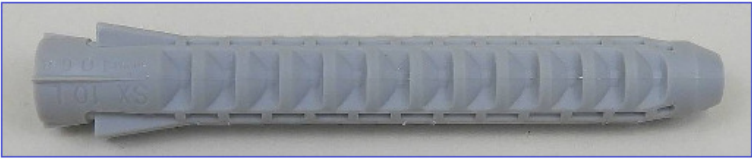

Article No.	Dimensions [mm]	PU
10x50 SX-D	10x50mm Dowel	100
10x80 SX-D	10x80mm Dowel	100

Heavy-Duty Dowel



Article No.	Dimensions [mm]	PU
8x71 HD-D	Ø8x71 Heavy-Duty Dowel	100

Force calculation, location of blocks and technical data.

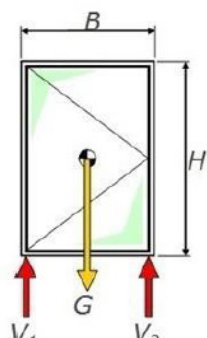
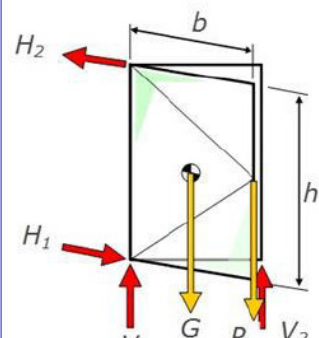
Forces at the window plane (V) or casement level (H)					
<p>Casement closed, forces:</p>  $V_1 = V_2 = \frac{G}{2}$	<p>Casement barely opened, forces:</p>  $V_1 = \frac{G_{BR}}{2} + G_{FL} + P$ $V_2 = \frac{G_{BR}}{2}$ $H_1 = H_2 = \frac{b}{h} \cdot \left(\frac{G_{FL}}{2} + P \right)$				
<p>Legend:</p> <table style="width: 100%; border: none;"> <tr> <td style="width: 30%;">V_n, H_n supportinf forces</td> <td style="width: 30%;">B, H, b, h Element width, element height and/or casement width, casement height</td> </tr> <tr> <td>P_{\square} Vertical imposed load</td> <td>G_{\square} Self-weight, G_{BR} = Frame member, G_{FL} = Sash</td> </tr> </table>		V_n, H_n supportinf forces	B, H, b, h Element width, element height and/or casement width, casement height	P_{\square} Vertical imposed load	G_{\square} Self-weight, G_{BR} = Frame member, G_{FL} = Sash
V_n, H_n supportinf forces	B, H, b, h Element width, element height and/or casement width, casement height				
P_{\square} Vertical imposed load	G_{\square} Self-weight, G_{BR} = Frame member, G_{FL} = Sash				
<p>¹ Excerpt from „Guide for installation of windows and external pedestrain doors“, RAL-Quality Assurance Association Windows, Facades and Doors e.V, December 2016, page 96</p>					

The fastening points and fastening distances specified by the system supplier must be observed.

Dismantling of the forces acting at right angles to the window plane (wind load) and fixing points

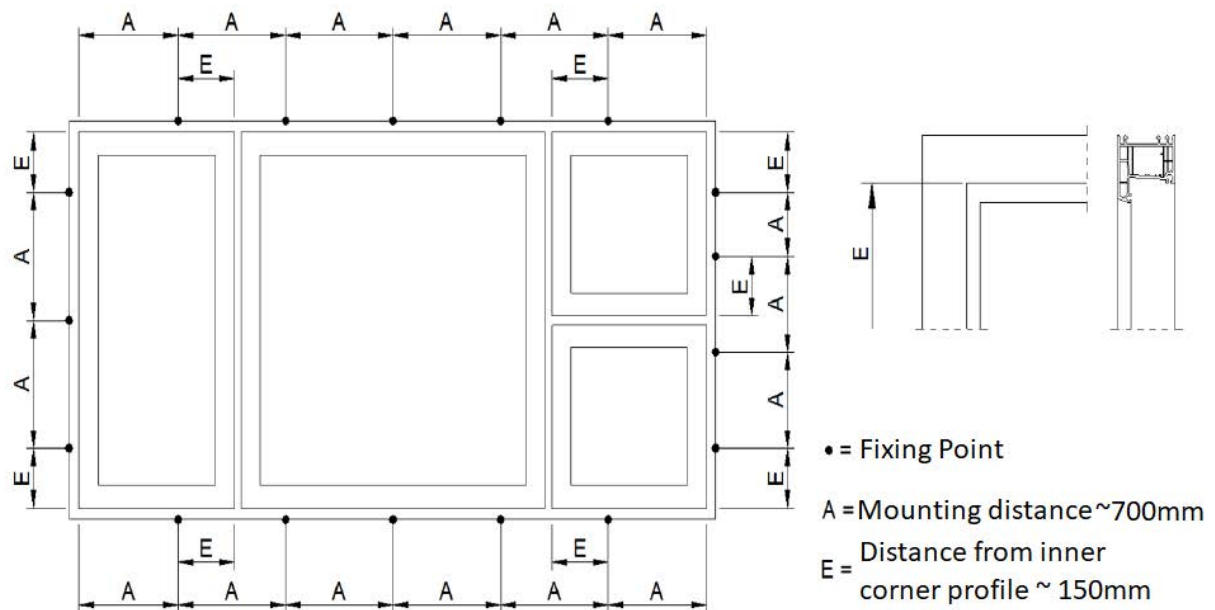

Removal of forces at the window level (own and traffic load)

NB: Static anchors has to be arranged like blockings!

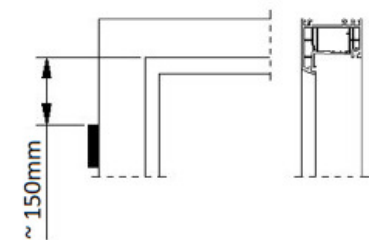
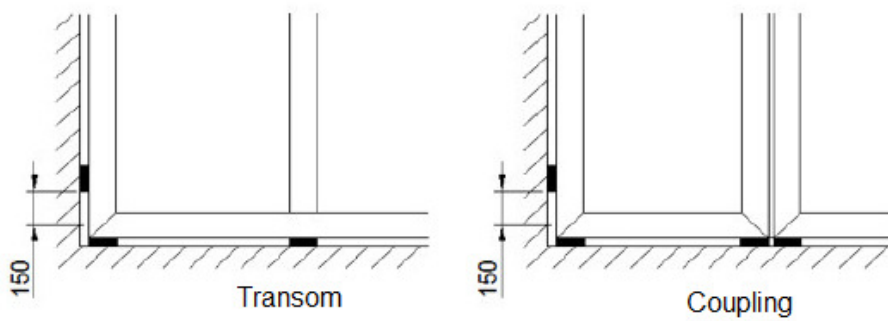
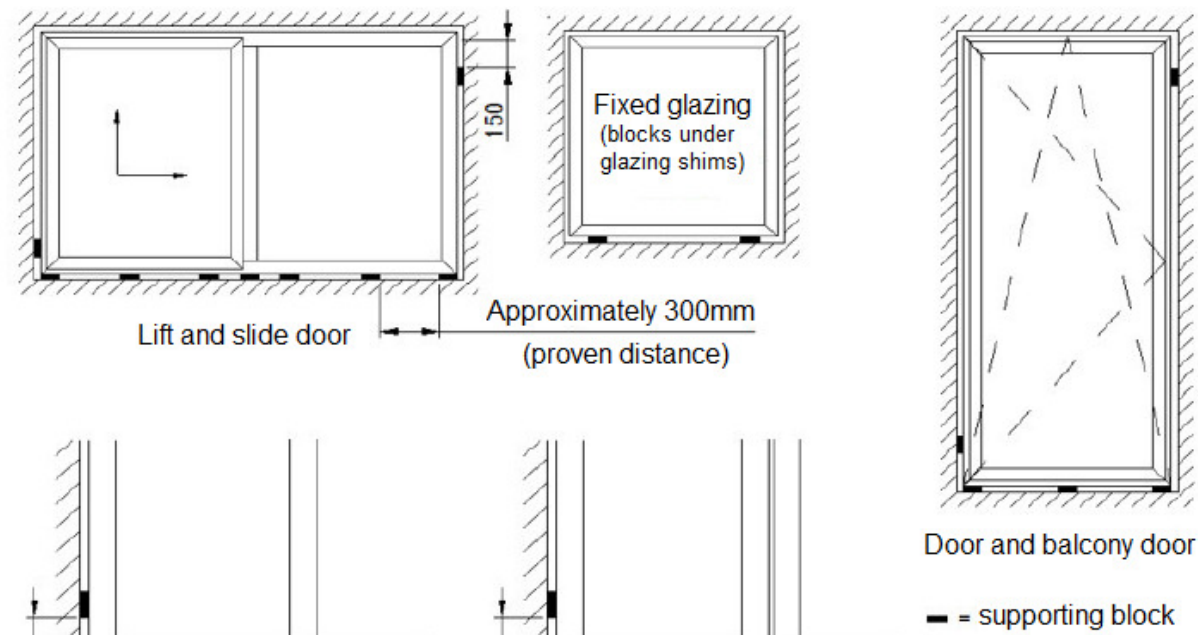
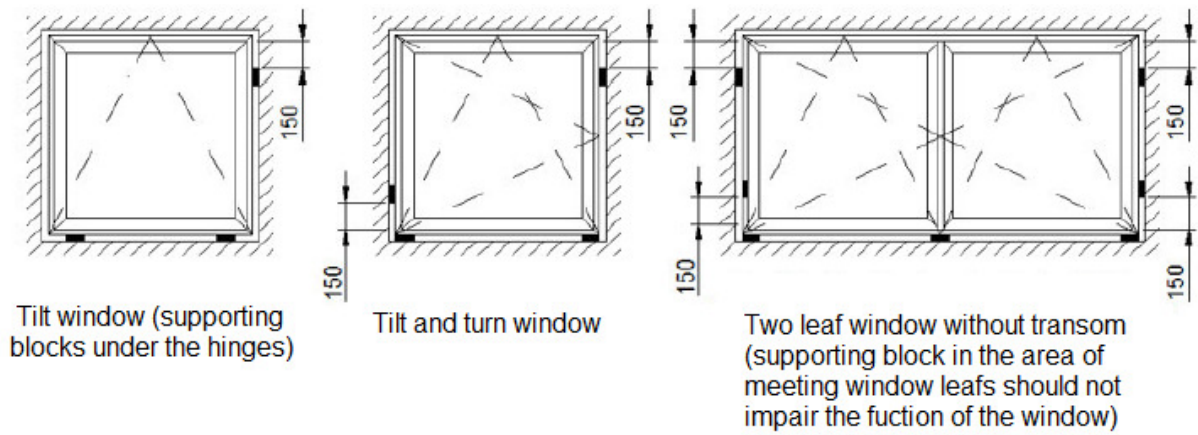

All metal anchors are zinck coated and regarding EN ISO 12944-2 are rated for external use corrosion class C3.

Coating is made by Gebhardt-Stahl GmbH.

Anchors are made in Germany.